

U. S. DEPARTMENT OF AGRICULTURE.

OFFICE OF EXPERIMENT STATIONS—BULLETIN NO. 167.

A. C. TRUE, Director.

IRRIGATION

IN THE

NORTH ATLANTIC STATES.

BY

AUG. J. BOWIE, JR.,

AGENT AND EXPERT.

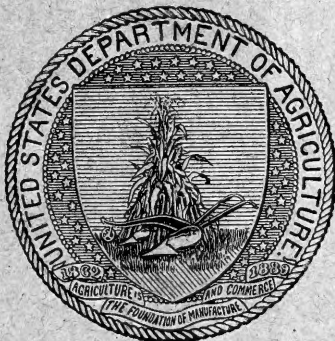

WASHINGTON:

GOVERNMENT PRINTING OFFICE.

1906.

S
615
B7



Class S615

Book .B7



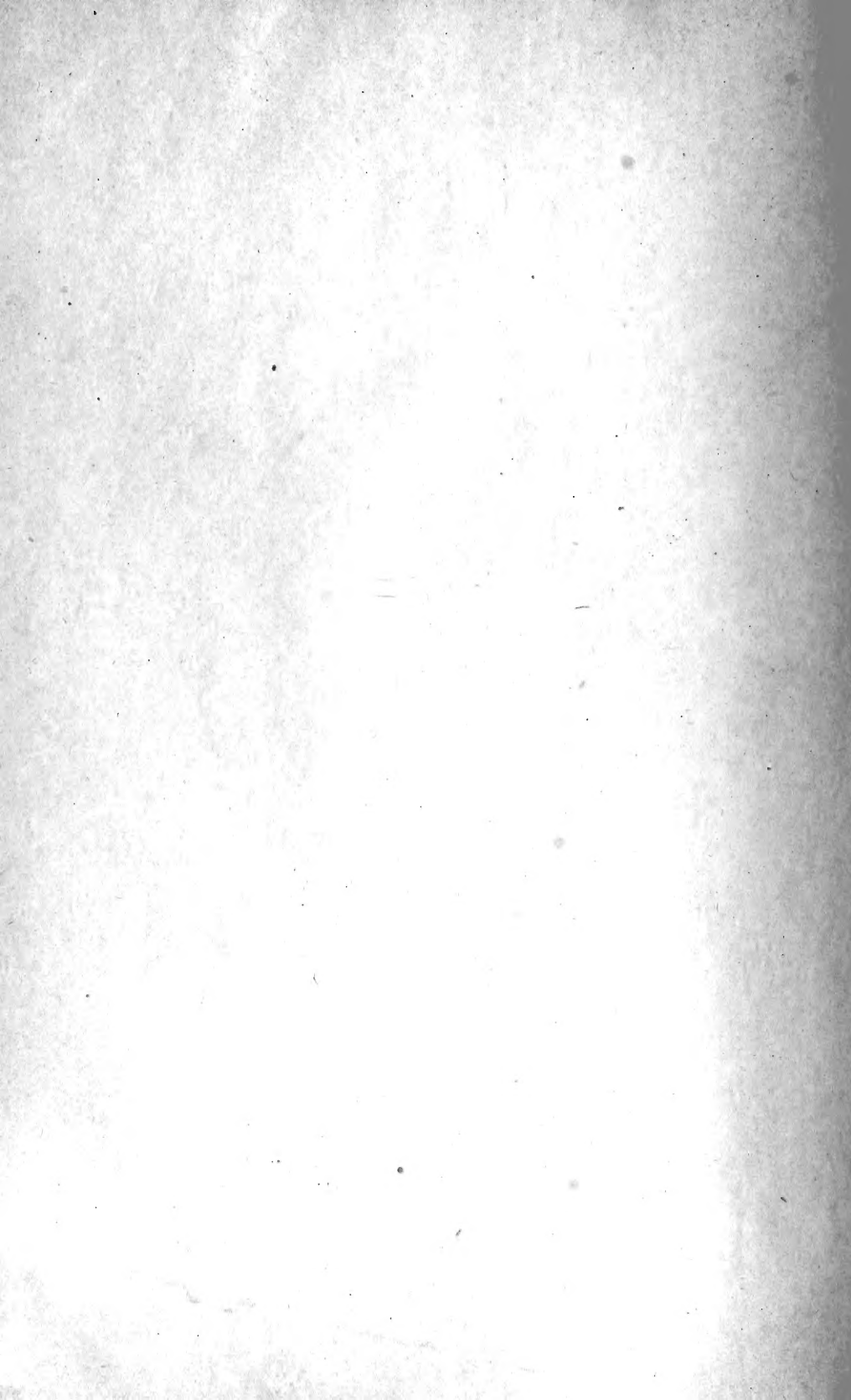

U. S. DEPARTMENT OF AGRICULTURE.

OFFICE OF EXPERIMENT STATIONS—BULLETIN NO. 167.

A. C. TRUE, Director.

520

IRRIGATION

IN THE

NORTH ATLANTIC STATES.

BY

Active
Base
AUG. J. BOWIE, JR.,
AGENT AND EXPERT.



WASHINGTON:
GOVERNMENT PRINTING OFFICE.
1906.

5615
B7

THE OFFICE OF EXPERIMENT STATIONS.

STAFF.

- A. C. TRUE, Ph. D.—*Director.*
E. W. ALLEN, Ph. D.—*Assistant Director and Editor of Experiment Station Record.*
W. H. BEAL, B. A., M. E.—*Chief of Editorial Division.*
W. H. EVANS, Ph. D.—*Chief of Division of Insular Stations.*
JOHN HAMILTON, B. S., M. S. A.—*Farmers' Institute Specialist.*
MRS. C. E. JOHNSTON.—*Chief Clerk.*

IRRIGATION AND DRAINAGE INVESTIGATIONS.

- ELWOOD MEAD, D. E.—*Chief of Irrigation and Drainage Investigations.*
C. G. ELLIOTT, C. E.—*Engineer in Charge of Drainage Investigations.*
S. M. WOODWARD, M. S., M. A.—*Engineer in Charge of Irrigation Investigations.*
R. P. TEELE, M. A.—*Expert in Irrigation Institutions.*
C. J. ZINTHEO, B. S.—*Expert in Farm Mechanics.*
SAMUEL FORTIER, M. E.—*Engineer in Charge of Pacific District.*
F. C. HERRMANN, B. S.—*Expert in Irrigation as Related to Dry Farming.*

(2)

JUL 20 1906
D. of D.

LETTER OF TRANSMITTAL.

U. S. DEPARTMENT OF AGRICULTURE,
OFFICE OF EXPERIMENT STATIONS,
Washington, D. C., April 16, 1906.

SIR: I have the honor to transmit herewith a report on Irrigation in the North Atlantic States, by Aug. J. Bowie, jr., of the Irrigation and Drainage Investigations of this Office. This report shows that for market gardens and for meadows irrigation in humid sections has proven profitable, but it has not yet been practiced in the raising of general farm crops. The cost of securing water supplies in the East far exceeds that in the arid regions, although water is much more plentiful. This suggests that it may be possible to so reduce the cost of water as to render irrigation profitable for many crops which will not repay the expense now incurred. The descriptions of irrigation practice contained in this report should be suggestive to many who are now raising truck without the aid of irrigation, and it is therefore recommended that the report be published as a bulletin of this Office.

Respectfully,

A. C. TRUE,
Director.

HON. JAMES WILSON,
Secretary of Agriculture.

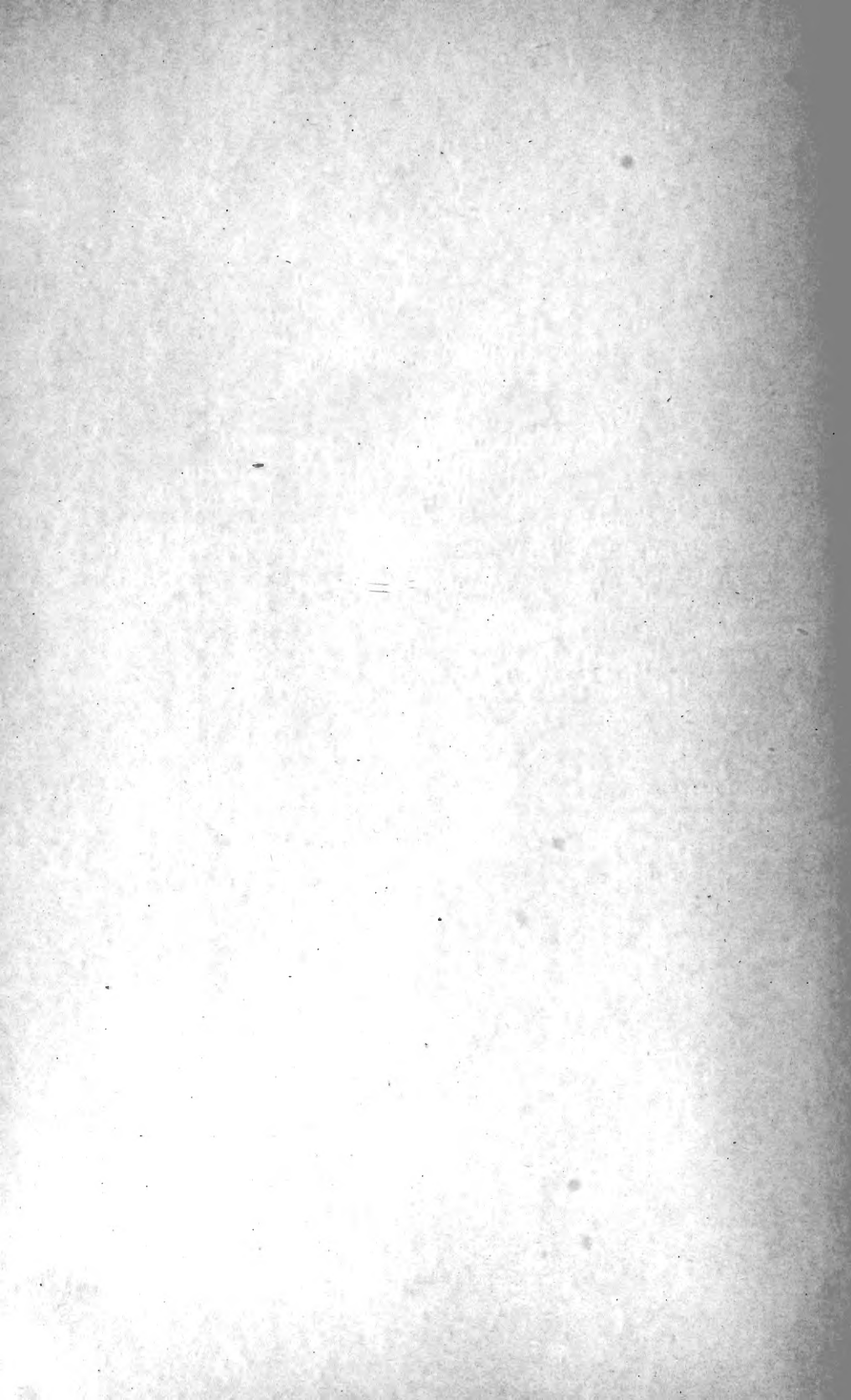

CONTENTS.

	Page.
Field for irrigation in humid climates.....	7
Topography.....	8
Rainfall.....	8
Water supply.....	9
Meadow irrigation.....	10
Lancaster County.....	12
Berks County.....	12
Lehigh County.....	13
Northampton County.....	14
Irrigation of truck farms.....	15
Detailed descriptions of irrigation plants.....	15
Maryland.....	15
Pennsylvania.....	16
New Jersey.....	22
New York.....	33
Massachusetts.....	37
Rhode Island.....	42
Methods of irrigation.....	44
The cost of irrigation.....	46
Returns from irrigation.....	49
Conclusion.....	50

ILLUSTRATIONS.

	Page.
FIG. 1. Sliding gate in flume.....	25
2. Carrier for pipe and sprinklers.....	26
3. Adjustable nozzle.....	39
4. Adjustable hydrant with hose and nozzle.....	40
5. Simple nozzle.....	46
6. Nozzle	47
7. Multiple sprinkler.....	48

IRRIGATION IN THE NORTH ATLANTIC STATES.^a

The data for this report were collected during July and August, 1905, and include a study of irrigation as practiced in Maryland, Delaware, Pennsylvania, New Jersey, New York, Rhode Island, and Massachusetts. The territory investigated lies in the humid district of the United States, where the annual rainfall is between 40 and 50 inches. Irrigation is not always necessary for the growth of crops and has been confined to truck farms and meadow land.

FIELD FOR IRRIGATION IN HUMID CLIMATES.

According to the popular conception, the field for irrigation is the arid or semiarid region in the West, and does not extend to the humid East, where the supply of moisture is considered sufficient for the growth of crops. The distribution of rainfall, however, is so uncertain that crops throughout the East often suffer from droughts. Without irrigation certain crops, such as strawberries, celery, and cauliflower, may be entirely lost. It is not uncommon to see farmers making frantic efforts to save their crops from destruction by hauling water and sprinkling from barrels and watering pots. The water applied in this manner is too small in quantity to be of any service and is very costly. Economical and successful methods of irrigation adapted to humid conditions are, however, quite extensively used and are described in this report.

The advantages to be gained from irrigation are limited to certain crops. Such field crops as timothy, clover, wheat, rye, oats, and corn are not particularly affected by droughts of short duration. The value of such crops in eastern Pennsylvania will usually lie between \$15 and \$30 per acre, and irrigation in such instances would hardly pay under present conditions. The case of truck crops is entirely different. The value of a single crop will often be \$200 to \$1,500 per acre, and usually two to three crops are grown on the same land in a year. Crops of this nature are much more sensitive to drought than field crops. Particularly is this true in the case of berries during the time when the fruit is maturing. Failure to provide sufficient moisture during this period may result in very great damage to the crop.

^a Previous studies of irrigation in the East have been reported in U. S. Dept. Agr., Office of Experiment Stations Buls. 36, 87, 119, 133, 148, and Farmers' Bul. 46.

The irrigation of truck not only greatly increases the yield, but it matures the crops earlier, when they will bring higher prices, and may allow the growth of one more crop during the year. It is particularly during the years of greatest drought that the truck farmer who irrigates reaps his harvest, when prices are highest and his neighbors' crops poorest in quantity and quality. The distribution of rain is by no means uniform, even in adjoining counties, and certain localities, owing to the topography of the land, fail to receive many of the showers which fall on the surrounding country.

It is commonly said that truck irrigation will pay only when the market is close at hand, but much of the data presented show good returns from the irrigation of truck land rather unfavorably situated. In addition to truck gardens there are in many localities low meadow lands which may be cheaply irrigated, and these two types of irrigation practice constitute the present field for irrigation in the humid East.

TOPOGRAPHY.

The land of the humid belt in the eastern and northeastern part of the United States is generally of a rolling hilly nature, totally unlike the broad level plains and valleys of the West. The difficulties of preparing for irrigation large sections of land are correspondingly greater. Comparatively few large farms, however, are found through the East, the land being cut up into smaller holdings. Of the territory investigated, eastern Maryland, Delaware, southern and eastern New Jersey, and Long Island are fairly level, while in eastern Pennsylvania and northwestern New Jersey the land is nearly all hilly.

RAINFALL.

The following table is taken from the Weather Bureau reports to show for the section investigated the large variations in the annual and seasonal rainfall for the last ten years. The "normal" rainfall is simply the average since records have been kept.

Annual and seasonal rainfall in eastern cities from 1895 to 1904.

Year.	Boston.		New York.		Harrisburg.		Philadelphia.	
	Annual.	April to September.	Annual.	April to September.	Annual.	April to September.	Annual.	April to September.
1895.....	<i>Inches.</i> 40	<i>Inches.</i> 16	<i>Inches.</i> 36	<i>Inches.</i> 17	<i>Inches.</i> 26	<i>Inches.</i> 13	<i>Inches.</i> 31	<i>Inches.</i> 15
1896.....	38	18	38	20	35	18	32	14
1897.....	41	22	44	26	34	18	42	24
1898.....	50	25	45	19	45	26	49	24
1899.....	36	15	42	20	34	20	40	18
1900.....	44	19	42	19	29	15	41	22
1901.....	49	26	47	29	30	17	46	28
1902.....	34	13	47	21	40	18	50	22
1903.....	21	22	19	21
1904.....	40	42	32	40
Normal.....	45	22	45	22	44	24	40	21

It is seen that in dry seasons there is about half as much rain as in wet, and that about one year in three has less than 75 per cent of the normal rainfall. The following table shows the monthly rainfall during the crop-growing months for the same period and is inserted to show that even in seasons of normal or excessive rainfall, as in 1901 or 1903, there may be a dry month which will greatly retard growth.

Monthly rainfall in Philadelphia from 1895 to 1904.

Year.	April.	May.	June.	July.	August.	September.	Total.
	<i>Inches.</i>	<i>Inches.</i>	<i>Inches.</i>	<i>Inches.</i>	<i>Inches.</i>	<i>Inches.</i>	<i>Inches.</i>
1895.....	6.1	1.7	3.2	3.2	0.6	0.6	15.4
1896.....	1.2	2.3	4.1	3.3	.5	2.8	14.2
1897.....	3.0	4.3	4.5	7.7	3.5	1.1	24.1
1898.....	2.9	4.8	1.8	3.6	9.1	1.8	24.0
1899.....	1.0	2.3	1.1	4.7	5.2	3.7	18.0
1900.....	1.9	4.1	2.8	2.8	4.0	6.3	21.9
1901.....	4.8	4.1	1.2	4.9	9.4	3.7	28.1
1902.....	3.3	2.0	6.1	3.5	2.3	5.0	22.2
1903.....	3.0	.9	5.5	3.8	5.6	2.3	21.1
1904.....	2.9	3.8	4.4	7.2
1905.....	3.6	1.8
Normal.....	3.0	3.2	3.1	4.2	4.3	3.3	21.1

WATER SUPPLY.

Most of the irrigated meadow land in Pennsylvania lies near the beds of small creeks fed by springs. The flow of the springs varies considerably during the year, many of them drying up, so that part of the year the water supply is insufficient for irrigation, or ceases altogether. Small dams constructed of timber back filled with earth are built to raise the water sufficiently high to cover the land, but not for storage. They are usually small affairs, cheaply constructed, costing from \$5 to \$20. When washed out they are often not replaced for a year or two, the land meanwhile going unirrigated.

The use of wells as a source of irrigation is quite limited, and throughout the East the absence of windmills is particularly noticeable. The cost of well boring is considerably higher than in the South and West.

Many farmers near the large cities use city water for irrigation, since, if the farm is small and the use of water is limited, it is thought to be cheaper than pumping. The usual cost of such water is \$1 to \$1.50 per 1,000 cubic feet, or \$44 to \$65 per acre-foot—a price which would certainly seem prohibitive to western irrigators, some of whom pay less than 1 per cent of these costs, and even where pumping is practiced, as in Santa Clara Valley, California, the average cost of raising water 65 feet is only \$4.40 per acre-foot, or 10 per cent of the above price. The success of irrigation under the conditions found in the East is due not to cheap water supply, but to the high value of crops grown and the careful distribution of the small quantity of water used.

MEADOW IRRIGATION.

The table given below gives the location and area of 125 irrigated meadows in four counties of Pennsylvania, with such data as could be obtained regarding their yield and the yield of similar land without irrigation:

Irrigated meadows in Pennsylvania.

Name.	County.	Area.	Yield per acre.	
			Irrigated.	Nonirrigated.
		Acres.	Tons.	Tons.
B. Caskey	Lancaster	7		1
Elias Breckbill	do	5	2	
J. Keener	do	2		
J. Bachman	do	9	2.4	
David Myers	do	1		
J. Mellinger	do			
Newt. Herr	do	7	2	1
John Beiler	do	4	2	1.5
Sam Martin	do	3	.8	.6
Jacob Zimmerman	do	5		
Joe Weaver	do	4		
David Martin	do	5		
David Rut	do	3		
A. H. Weaver	do	2		
C. H. Zimmerman	do	8	2.8	1.4
Frank Weaver	do	3		
Joe Weaver	do	3		
I. G. Martin	do	2	2.2	1.1
Amos Hostetter	do	10	2.9	
J. W. Morrison	do	2	3.2	1.6
Jacob Thomas	do	5		
H. Yoder	Berks	35	2.9	.6
J. H. Ruth	do	16	1.5	1.5
State Insane Asylum	do	65	3	
Reading Poorhouse	do	30	1.5	.7
F. J. Trexler	do	3	2.4	1.2
C. B. Adams	do	3	1.5	1
John Sell	do	2	2.3	
Peter Swoyer	do	3	2.7	
Abe Schlegel, jr.	do	1		
Do	do	5		
Aaron Houck	do	4	2.3	1.1
Eph. Leh	do	4		
William Edinger	do	3		
Jim Andy	do	2	2.5	1.5
Osser Houseman	do	1		
J. D. Kuser	do	6	Double.	
Emma Hassler	do		1.6	
W. Keim	do	5	2.9	.5
Sarah Butz	do	8	2.2	.9
John Bechtel	do		2.2	1.5
William Wolfgang	do	9	2	
J. K. Mest	do	4	2	.7
Jacob Moyer	do	3	1.5	.8
Alvin Weller	do	3	2.3	
Aaron Weller	do	2		
Mathias Miller	do	2	3.1	1.3
David Yoder	do	3	5	2.4
Joe Moyer	do	2		
Sam Wise	do	10	1.5	.8
Ephraim Weller	do	3	2.3	1.1
R. S. Gilbert	do	8	1.5	1.1
William Landis	do	5	2.4	
E. B. Yingting	do	3	2.5	1.2
Calvin Shane	do	4	2	
H. Wolfgang	do	5	2.1	1
G. W. Amey	do	5	2.6	
Jacob Knecht	do	5	2.5	
John Hufford	do	20		
Jacob Kulp	do	8	1.5	
Henry Apple	do	8	1.9	.9
M. T. Hess	do			
Jake Moyer	do	8	2.3	
John Fluck	do	5	3	
John H. Ruch	do	5	1.8	.9
Noah Geissinger	do	2	2.5	1.2
Newt. Moyer	do	13	2.9	1.4

Irrigated meadows in Pennsylvania—Continued.

Name.	County.	Area.	Yield per acre.	
			Irrigated.	Nonirrigated.
		Acres.	Tons.	Tons.
John Moyer	Berks	8	2.1	1
John Efnst	do	12		
P. H. Carl	Lehigh	2	1.5	1
C. H. Kline	do	4	1.8	.9
F. Gehman	do	3	2.7	
John Rothenberger	do	2	2.8	
D. M. Shantz	do	2	3	1.4
J. Rhoad	do	8	3	
J. C. Ackerman	do	8	3	1.4
H. B. Schelly	do	1	2	.9
Schuler Brothers	do	7	2.1	1
L. Ritter	do	8	1.6	
H. D. Gross	do	5	2.2	1.1
Jacob Young	Northampton	8	1.8	1.4
J. M. Weiss	do	3	1	
James P. Abel	do	6		
Sol S. Stevens	do	29	1.7	
F. O. Border	do	1		
T. L. Laubach	do	10	2	
W. V. Schweitzer	do	15	3	
Tom Kunsman	do	2		
A. H. Skinner	do	2		
T. F. Kunsman	do	6	1.7	
H. Illick	do	10		
J. J. Detweiler	do	4		
J. Davis	do	13		
T. Mitman	do	10		
William Ruch	do	8		
B. F. Fulmer	do	3		
A. Cressman	do	8		
John Rodenbach	do	7		
Preston Roth	do	5		
J. P. Kline	do	4		
David Unangst	do	5		
Howard Yelles	do	8		
Frank Rigg	do	6		
William Cautley	do	10		
A. T. Kunsman	do	5		
A. T. Burkstrasser	do	5		
Theo. Floubach	do	11		
John Boyer	do			
William Herrmann	do	12		
Mrs. Lurch	do	5		
William M. Applegate	do	7		
Dr. O. B. Schaeffer	do	6		
J. Fancboner	do	6	2	1.2
Will Fancboner	do	6	1	
Ben Buzzard	do	7	3	1.4
A. W. Sandt	do	2	2.3	
Julius Karabinus	do	7		
Alfred Remaley	do	15		
Charles Holland	do	6	2	
J. F. Engler	do	1	2	
J. Rush	do	3	2.2	.8
Franklin Hester	do	5	4	
R. D. Good	do	12	3	
— Strohe	do	4	4	
O. H. Emery	do	10	3	
Hiram and G. A. Yetter	do	10		

The entire area included in the table is over 800 acres, showing that meadow irrigation is a well-established practice in this region. In the 41 cases where an estimate of the yield from similar land not irrigated is given, 270 acres are reported as producing 570 tons of hay when irrigated and 270 tons when not irrigated, showing that irrigation is thought fully to double the yield.

More detailed data regarding a few typical meadows are added below to give a general idea of the methods employed.

LANCASTER COUNTY.

B. Caskey irrigates 7 acres, which yield 2 tons of hay to the acre in two cuttings. Water is run continuously over the same piece for about three weeks.

David Martin and four others irrigate 19 acres from Blue Ball Run. The water is diverted into a partnership ditch 3 feet wide and 2 feet deep, nearly a mile in length, which was built seventy years ago. Water is usually applied twice before each cutting and once immediately afterwards and runs continuously for three or four days for each irrigation. It is distributed over the land by means of small cuts in the side of the ditch, 12 to 15 feet apart. Where the ditch runs on a steep grade, boards or stakes are inserted to check the water. Repairs are said to cost \$5 a year. Three acres yielded 10 tons of hay or three times the yield of unirrigated land.

A. H. Weaver irrigates 2 acres from a spring. Water is run continuously for five days on the same piece of land, being applied in eight irrigations a month apart. After each irrigation the land is allowed to dry for two days, when stock is turned in to graze for the next three weeks. Irrigated land will pasture 3 head of stock per acre, whereas nonirrigated land will support only 1 head. The owner estimates the value of irrigated pasture per head per month at \$2, and of nonirrigated pasture where the quality of grass is not so good at \$1.50. Hence, allowing for the week during which irrigated land is not available for pasturage, the annual value of irrigated meadow land in the seven months from the middle of April to the middle of November is \$31.50 per acre, while the annual value of nonirrigated meadow land per acre is \$10.50. The annual cost of applying water to the land is but \$4; hence the net annual return is approximately \$17 per acre for irrigated land.

Amos Hostetter irrigates 10 acres, which is cut twice and pastured. The yield per acre is about 3 tons. Irrigation is begun about the 1st of June, and the first crop cut about ten days later. Water is run continuously from one to two days on the same piece of land and is usually applied every week. The crop of hay on nonirrigated land is hardly worth cutting. It takes one man two and a half days to clean the ditch each year.

J. W. Morrison irrigates 1½ acres, which yield 5 tons a year in two cuttings. Irrigation fully doubles the yield. Water is applied every ten days and runs continuously on the same piece of land for five days. The cost of the irrigation per year is about \$5.

BERKS COUNTY.

At the Reading poorhouse there are irrigated 30 acres, yielding 1½ tons to the acre in one cutting in June, after which the land is pastured. Water is run continuously from the middle of March to the middle of

June, and about the end of June the first crop is cut. If the weather remains dry the land is irrigated for pasture. Irrigation doubles the yield.

At the State Insane Asylum there are irrigated 65 acres of grass with sewage water, which is pumped into a reservoir on a hill and distributed through pipes and 2½-inch canvas hose, from which the water discharges freely over the land. The yield of hay is 2½ tons per acre. This irrigation plant is described at length on page 16.

Mrs. Sarah Butz formerly irrigated 8 acres yielding about 3 tons per acre in two cuttings. An embankment for a trolley-line has recently been erected through the farm, and as no provision has been made for conveying the water through the embankment the farm was not irrigated the past year, with the result that the yield was reduced to less than a ton per acre.

G. W. Amey irrigates from a spring 5 acres, which yield two and sometimes three crops, or a total of 13 tons per year. The owner believes that irrigation doubles the crop. The same piece is irrigated continuously for a month.

In the vicinity of Richlandtown are a few farms where meadow land is irrigated by surface drainage from the roads. No reliable figures, however, could be obtained of the value of such irrigation.

Jacob Knecht irrigates 5 acres, which yield 1½ tons per acre. The crop from nonirrigated land is hardly worth cutting. The land in the past has been irrigated once a week, the water running continuously for three days on the same piece. The owner thinks the water should be changed every day and that the farm has suffered from overirrigation. A considerable growth of sour grass, which is mainly due to overirrigation, may be seen in many other places throughout the country.

LEHIGH COUNTY.

C. H. Kline irrigates 4 acres, yielding nearly 2 tons per acre in two cuttings. Nonirrigated land has only half this yield. Water is applied continuously for five days, every three weeks, the first crop receiving six irrigations and the second crop four.

J. C. Ackerman irrigates 8 acres, yielding 2 tons per acre for the first crop and 1 ton per acre for the second crop, after which the land is pastured. The land is irrigated once a week, the water running continuously for a day on the same piece. The first crop receives twelve irrigations, starting in April, and the second crop eight. The time required to change the water is not over a quarter of an hour a day. Twenty-five head of cattle are wintered on the hay from 8 acres.

NORTHAMPTON COUNTY.

W. V. Schweitzer irrigates 15 acres, which have been irrigated 45 years. The first crop is cut early in June and yields $1\frac{1}{2}$ tons per acre; the second crop yields 1 ton, the third crop $\frac{2}{3}$ of a ton. After the third crop is cut the land is irrigated when necessary and then pastured. The water supply is obtained from the stream which supplies the mill and is used when the mill is not in operation. One tract of meadow land was fertilized by the addition of 300 pounds of fertilizer and ashes to the acre, increasing the yield materially. On the average irrigation increases the yield of the land threefold. Every third year the meadow is cut only twice in order to allow the grass to reseed itself, the first cutting being made about June 24. In the early spring when water is plentiful the land is thoroughly fertilized by opening a large drainpipe in the headrace and washing over the land the mud and sediment gathered there.

A. H. Skinner has two 4-acre pastures; while one is being irrigated the other serves as pasture. One irrigation lasts for six weeks, and one irrigated pasture will support 8 head of cattle, whereas nonirrigated land will support only half as many.

The data given are enough to show that the crude methods used for meadow irrigation are successful, and on the small scale at present practiced are cheap to install and operate. They suggest but do not demonstrate what could be done with a well-built system on a large tract. Many of the meadows have suffered from overirrigation, shown by a growth of sour grass in spots. This usually indicates uneven watering rather than an excess of water on the whole tract, and in many cases could be remedied by running small furrows down through the field, 4 or 5 feet apart, with a single shovel or a special cultivator attachment cutting through the turf. They should have grade enough to carry the water easily and may often be run from the head ditch in the direction of the greatest slope. This method is very common in Utah and Nevada for all field crops, where the inconvenience in mowing across the furrows and the loss of grass or alfalfa in the furrows is found to be very small.

IRRIGATION OF TRUCK FARMS.

The following list of truck farms, most of which are described later in detail, shows the location and area of each farm. These farms are referred to in the subsequent discussion by their numbers, as given in the list below:

Irrigated truck farms.

No.	Name.	State.	County.	Area.
1	Louis Chassagne.....	Maryland	Baltimore.....	Acres. 6
2	N. H. Mack.....	Pennsylvania	Lancaster.....	4
3	State Insane Asylum.....	do	Berks.....	105
4	P. B. Dilks.....	do	Philadelphia.....	3
5	M. V. Dilks.....	do	do.....	1
6	Alfred Paul.....	do	Montgomery.....	1
7	U. J. Weand.....	do	Lehigh.....	4
8	John F. Weaver.....	do	Northampton.....	3.5
9	Ed C. Schaefer.....	do	do.....	4
10	Julius Karabinus.....	do	do.....	1
11	J. F. Engler.....	do	do.....	1
12	Harry Broadhead.....	do	Monroe.....	0.3
13	R. F. Schwarz.....	do	do.....	5
14	M. Garrahan.....	do	Luzerne.....	9
15	Mrs. R. C. Shannon.....	do	Northumberland.....	2
16	W. J. Suter.....	do	do.....	2
17	C. McWilliams.....	do	do.....	1.5
18	F. W. Kilbourne.....	New Jersey	Middlesex.....	2
19	W. P. Stokes.....	do	Burlington.....	5
20	Henry A. Dreer.....	do	do.....	5
21	T. R. Hunt.....	do	Hunterdon.....	6
22	David Astle.....	do	Cumberland.....	1.6
23	Cuno Becker.....	do	do.....	16
24	State Asylum for Feeble-Minded Children.....	do	do.....	3
25	William Ash.....	do	do.....	10
26	George Mitchell.....	do	do.....	1
27	J. H. Shute.....	do	Gloucester.....	3
28	L. M. Parkhurst.....	do	Atlantic.....	10
29	Hermann Graumann.....	do	do.....	6
30	John I. Sickles.....	do	Monmouth.....	12
31	Julius Roehrs.....	do	Bergen.....	15
32	William Young.....	do	Essex.....	10
33	F. J. Forthuber.....	do	do.....	15
34	Henry Schumacher.....	do	Morris.....	10
35	John Wilhelm.....	do	Hudson.....	2
36	Arthur Robinson.....	do	do.....	15
37	W. Gurnheit.....	do	do.....	7
38	F. Schumacher.....	New York	Queens.....	15
39	Phillip Bach.....	do	do.....	18
40	Witte Bros.....	do	do.....	3
41	B. H. Mohlenhoff.....	do	do.....	4
42	August Plenge.....	do	do.....	4
43	John Schumacher.....	do	do.....	4
44	Bender Bros.....	do	do.....	17
45	Frank Coolidge.....	Massachusetts	Middlesex.....	100
46	W. W. Rawson.....	do	do.....	40
47	Weyman Bros.....	do	do.....	40
48	James Purcell.....	do	do.....	10
49	W. H. Allen.....	do	do.....	95
50	Hittinger Fruit Co.....	do	Suffolk.....	10
51	C. H. Slade.....	do	do.....	1
52	A. H. Long.....	do	do.....	10
53	H. W. Locke.....	do	Middlesex.....	2
54	Lovell Bros.....	do	do.....	6
55	Pierce Bros.....	do	do.....	26
56	J. W. Russell.....	do	do.....	22
57	D. N. Potter.....	Rhode Island	Providence.....	32
58	C. W. Patt.....	do	do.....	

DETAILED DESCRIPTIONS OF IRRIGATION PLANTS.

MARYLAND.

No. 1. Louis Chassagne, of Baltimore County, irrigates 6 acres of garden truck with water from the city main, costing 6 cents per thousand gallons, or \$19.50 per acre-foot. In 1904, 4 acres were irrigated,

and in 1905, owing to the wetness of the season, only one-half acre. The soil is a sandy loam 12 inches thick, with a sandy subsoil. The furrow system and sprinkling are both used. In very dry weather the land is irrigated every two weeks and is sprinkled twice a week, receiving at most not over three irrigations per crop. The furrows are 18 to 24 inches apart and 200 feet long. The water supply is sufficient to water 1 acre to a depth of $5\frac{1}{2}$ inches in forty-eight hours. This is the maximum quantity of water applied at one irrigation, and frequently half this quantity is sufficient. The depth applied by sprinkling is very small compared with this. The ground is piped with $1\frac{1}{2}$ -inch second-hand piping, which cost \$200.

The crops irrigated are celery, lettuce, and cauliflower, the celery being only sprinkled. The cost of labor is \$4.50 per week and board. The owner estimates that in some years irrigation increases the returns fully \$1,000, and that as a rule it doubles the yield. The value of the crops irrigated, per acre, are: Celery, \$350 to \$500; lettuce, \$150; cauliflower, \$200; celeriac, \$300 to \$500. During a drought irrigated cauliflower is cut two weeks earlier than unirrigated, and it brings twice as high a price. In 1904 celeriac not irrigated was hardly marketable. Irrigated beets were ten days ahead of those not irrigated. In the drought of 1901 the crop from 1 acre of irrigated lettuce sold for \$400, at 75 cents to \$1.25 per bushel. Unirrigated lettuce was a total failure. The cost of water was \$40 in 1904 and \$6 in 1905.

PENNSYLVANIA.

No. 2. At the Welsh Industrial Mission 4 acres in strawberries are irrigated from a spring by the furrow system. The land usually receives two irrigations a week apart. The water requires three to four hours to run through the furrows, which are 260 to 300 feet long and $3\frac{1}{2}$ feet apart, the plants being set 18 inches apart. The yield of irrigated berries is 4,800 boxes per acre, the average price being from 5 to 10 cents per box. During a dry season a few years ago berries brought 7 to 15 cents a box, \$336 to \$720 an acre, at a time when the entire crop in the valley below was a failure. The superintendent, Mr. Mack, does not attribute the results wholly to irrigation, but estimates that it produces an increase of 25 bushels, or 800 boxes, per acre, since the soil and climate at the mission are more favorable than in the valley. In 1904 but 2 acres were irrigated.

No. 3. The State Insane Asylum at Wernersville irrigates 105 acres with sewage, the disposal of which is the primary object of the plant. Sixty-five acres are in grass, yielding $2\frac{1}{2}$ tons per acre, and 40 acres in potatoes, yielding 150 bushels per acre. The sewage is distributed from a reservoir through $2\frac{1}{2}$ -inch and 3-inch pipe, to which a $2\frac{1}{2}$ -inch hose is attached every hundred feet for distributing the water.

Furrow irrigation is used for potatoes, and flooding down the slope for grass.

No. 4. P. B. Dilks has a 3-acre irrigated farm near Philadelphia, the water being supplied by a pumping plant. A triplex double-acting pump delivering 50 gallons per minute is driven by a 4-horsepower gasoline engine. Water is lifted 14 feet and forced through 600 feet of 2-inch pipe. The plant is usually operated twelve hours per day, in which time 1 acre is irrigated to a depth of 1.3 inches. Sometimes only half this depth is used. The engine is not loaded to its capacity and consumes but 2 gallons of gasoline in twelve hours. The engine and pump cost \$500, pipe and hose \$300, making the total cost of the plant \$800. Two-inch piping costs 20 cents per foot.

The crops irrigated are celery, cabbage, and lettuce, and in very dry seasons beets and radishes. The entire flow of the pump is turned into one furrow, and takes ten to thirty minutes to run through. The furrows vary in length from 200 to 350 feet and are 2.5 feet apart. Occasionally the ground is sprinkled to kill lice on the celery or lettuce. Celery is irrigated once a week in dry weather, requiring three to four irrigations in a season. In dry weather irrigated celery and cabbage gave excellent yields, while unirrigated crops were a failure. Irrigated lettuce was 75 per cent better than unirrigated. One acre of celery will bring on an average \$300, and 1 acre of cabbage \$400, the price usually received for cabbage being \$1 per barrel. Cabbage is irrigated in dry weather only when heading. The owner estimates that this single irrigation fully doubles the yield, and that the value of the celery crop is also doubled by irrigation.

No. 5. M. V. Dilks, on an adjoining farm, irrigates an acre of truck with water from the city waterworks. The flow is about 18 gallons per minute and the cost of the water \$30 per year.

No. 6. Alfred Paul, of Montgomery County, irrigates one-half acre of strawberries with water from a spring, applied by the furrow system. The net returns from the crop were \$250. Irrigation is said to double the value of the crop, and in 1905 it would have been a failure without water. Water is applied during the night, the irrigation season lasting only about two weeks. The total cost of developing the water supply was \$50.

No. 7. U. J. Wieand, of Lehigh County, has a pumping plant for 4 acres of strawberries and potatoes. The plant consists of a 5-horsepower motor taking its power from a trolley line, and a No. 2 centrifugal pump delivering 165 gallons per minute against a 24-foot lift. It takes twenty-four hours to irrigate the 4 acres by the furrow system, making a depth of 2.2 inches. Mr. Wieand intends to install a 15-horsepower motor for the irrigation of 100 acres to be planted in rye, hay, and potatoes. He estimates that the irrigation season for potatoes would last six weeks.

No. 8. John F. Weaver, of Northampton County, irrigates 3.5 acres with water raised by a No. 6 ram. During extreme dry weather the supply is sufficient for 1.5 acres, and occasionally for 2 acres additional. Water is supplied to the ram under a 20-foot head and is elevated 185 feet to a tank of boiler iron $4\frac{1}{4}$ by 8 by 7 feet. The ram is fed through 160 feet of $2\frac{1}{2}$ -inch pipe and discharges through 2,000 feet of $1\frac{1}{4}$ -inch pipe into the tank. The standpipe is 550 feet from the ram, which fills the tank in six hours, corresponding to a flow of 2 gallons per minute. The $1\frac{1}{4}$ -inch pipe is buried in wooden chips and sawdust to prevent freezing. The water is distributed by hand sprinkling and by a four-arm revolving sprinkler, which is moved every half hour or hour. The tank full and the supply of the ram will irrigate one-quarter acre in twelve hours by the latter method. Tomatoes, cabbage, and beans are irrigated occasionally; celery, lettuce, and radishes are irrigated about every seven days in dry weather. Lettuce and Lima beans receive 4 irrigations, radishes 3, cabbage 1, and celery 12 in a dry season. It takes six weeks to raise lettuce and five weeks to raise radishes when the ground is irrigated just before planting.

Irrigation doubles the tomato and cabbage yields in average seasons, and in 1905 without irrigation there would have been no crop of lettuce, Lima beans, or celery. One-third acre of lettuce yielded in two crops 12,000 heads, which sold for from 2 to 8 cents apiece, the average price being 4 cents. An acre of radishes brought \$750 in three crops in 1905, the price being 5 cents per bunch retail and 3 cents wholesale in a dry year. The wholesale price in average years is $1\frac{3}{4}$ cents per bunch. Early cabbage is planted 16 inches apart in $2\frac{1}{2}$ -foot rows. In 1904, 5,000 plants yielded 200 barrels. In 1905, owing to insufficient water supply, the yield was only 150 barrels. Tomatoes yielded 1,200 baskets per acre, the price in average years being 20 cents per basket. In 1905 the price was \$1.25 per basket. Beans are irrigated from April through September. In 1905 the celery raised by irrigation was the finest ever grown on the place in size and weight. A bunch of twelve plants weighed 16 pounds, which at the price obtained, \$5 per 100 pounds, made the yield per acre worth \$1,000. The owner believes that besides hastening it irrigation doubles the crop.

The total cost of the plant, including ram, pipe, and 1,500 feet of additional $1\frac{1}{4}$ -inch pipe used for the distribution of the water and the $\frac{3}{4}$ -inch and 1-inch hose used, was \$850. The cost of labor is 75 cents per day and board, and the irrigation of an acre requires six days.

No. 9. Ed C. Schafer, Northampton County, irrigates 4 acres with water pumped by a No. 8 hydraulic ram fed through 75 feet of $3\frac{1}{2}$ -inch pipe. The water supply for the ram is under 11-foot head and the discharge is elevated 80 feet through 575 feet of $1\frac{1}{4}$ -inch pipe into a

cistern 8 by 8 by 8 feet, which is filled in eight and one-half hours, corresponding to a flow of $7\frac{1}{2}$ gallons per minute. Water is distributed by 1,000 feet of $1\frac{1}{4}$ -inch and 1-inch pipe with T's for outlets every 40 feet. The land is watered by sprinkling, partly by hand, but principally by the use of a small water witch fed by 1-inch hose. This will cover a circle 30 feet in diameter and in seventeen hours will irrigate one-half acre, being moved every hour. It delivers $3\frac{1}{2}$ gallons per minute. One hundred feet of 1-inch hose is used, half of which is replaced each year. The cost of the plant was \$180, of which the ram cost \$40, the feed pipe \$15, and 1,000 feet of 1-inch and $1\frac{1}{4}$ -inch piping \$125.

Lettuce planted in June is sold in August, bringing in 1905 6 cents a head. Unirrigated lettuce did not mature. Radishes planted in April were harvested June 1. In 1905 they sold for 5 cents per bunch; in 1904, for one-half or one-third as much. Radishes, lettuce, and beets were irrigated every two days. Onions and cabbages were not irrigated.

No. 10. Julius Karabinus, of Northampton County, irrigates 7 acres of meadow land and 1 acre of truck from a creek across which a concrete dam has been constructed at a cost of \$340. The dam is 84 feet long, with an average height of 4 feet. It is 4 feet wide at the base and 1 foot on top, with a rock foundation. It is provided with flashboards for raising the water level when desired, and has a wooden apron in front to take the impact of the water. Water is diverted through a ditch 4 feet wide and 2 feet deep, which carries about 4 cubic feet per second, a sufficient quantity to irrigate 400 acres in the arid region. No fixed system of irrigation was used, the water being distributed by wild flooding, some parts of the land being greatly overirrigated.

From one-half acre of truck 3,000 head of cabbage brought \$90, and 20 bushels of cucumbers brought \$20. Truck land was irrigated every other day; meadow land continuously. The owner believes that the profits of irrigation will soon pay the cost of the dam.

No. 11. J. F. Engler, of Northampton County, irrigates an acre of meadow land which in 1901 was planted in potatoes, yielding 80 bushels under irrigation. Unirrigated potato land yielded 90 to 100 bushels per acre. The land was irrigated by the furrow system every two weeks, the water flowing continuously for two days at a time in furrows 450 feet long. The crop undoubtedly suffered from overirrigation, resulting in decreased yield. In 1905 the yield from irrigated grass land was $2\frac{1}{2}$ tons per acre, while unirrigated yielded $1\frac{1}{2}$ tons per acre. In 1904, 1 acre of irrigated wheat land yielded 36 bushels, while unirrigated land of the same nature yielded 28 bushels.

No. 12. Harry Broadhead, of Monroe County, irrigates one-quarter acre of beets with water obtained from springs. The water runs into six 50-gallon barrels, which are used as reservoirs, whence it flows to

the farm through 500 feet of 1-inch pipe, the vertical head being 30 feet. The land is watered by means of a water witch fed through a $\frac{3}{4}$ -inch hose. The water witch covers a circle 20 feet in diameter, and is moved every half-hour. Water is applied once a week in dry weather. The water stored in the barrels and the flow of the spring is sufficient to operate one water witch for $3\frac{1}{2}$ hours. The owner thinks that irrigation has doubled the value of crops in average years.

On a farm near East Stroudsburg, at the time of the writer's visit, the celery crop had been set out only a short time, and was burning up in spite of attempts to irrigate by hauling water a short distance in a barrel. The time required was one hour per barrel. Eight barrels of water, holding 32 gallons each, or 34 cubic feet in all, were applied in two irrigations to one-quarter acre. This would correspond to a depth of 0.02 inch per irrigation, which is not sufficient to be of any advantage whatever. Figuring the time of a man and team at 32 cents per hour, the water cost \$10 per 1,000 gallons, or over \$3,000 per acre foot. This case is cited to show the folly of this method of irrigation except in setting out plants.

No. 13. R. F. Schwarz, of Monroe County, irrigates 5 acres of truck with water obtained from a spring on a sidehill near his farm. A timber dam 25 feet long forms a reservoir for the spring, from which the water runs to the farm through a half mile of 2-inch pipe, under a head of 150 feet. Part of the tract is irrigated every day and part every other day. With a flow of 10 gallons per minute, $1\frac{1}{2}$ acres can be irrigated in twenty-four hours. The furrow system is used, a hose supplying water to the ends of the furrows. Sometimes the ground is sprinkled, a large round sprinkler with small holes being used.

The crops irrigated are celery, cabbage, beets, lettuce, asparagus, raspberries, strawberries, radishes, and rhubarb. Cabbage is planted 15 inches apart in rows 2 feet apart. It sold in 1905 for 5 cents per head wholesale, and 6 to 8 cents retail. Celery was planted 6 inches apart in 3-foot rows. It sold for 5 cents per stalk, three-fourths of the crop maturing. Lettuce was planted 6 by 9 inches. In 1905 it brought 5 to 7 cents per head, and four crops were grown. Without irrigation it would be impossible to raise lettuce. Three crops of radishes were raised on the same land, spaced 7 inches apart. The cost of the entire system was \$200. In dry years irrigation pays many times the interest on the investment.

No. 14. M. Garrahan, of Luzerne County, irrigates 9 acres in celery with water pumped from a slough, with a direct-acting steam pump driven by a 15-horsepower portable steam boiler. The fuel used is anthracite coal, costing \$4 per ton. The fuel consumption in ten hours, the usual length of run, is 800 pounds. Labor costs \$1.50 per day. The pump operates against a vertical lift of 13 feet, and delivers water into a $2\frac{1}{2}$ -inch pipe 900 feet long, provided with outlets for distributing

the water over the farm. The pump is said to deliver 150 gallons per minute and will irrigate the entire farm in one hundred and twenty hours, giving a depth of about 4 inches. The soil is a yellow clay 8 inches deep, with a tough clay subsoil.

The methods of irrigation employed are flooding by hose and sprinkling, the latter being used when it is necessary to get over the ground rapidly and flooding when more time can be allowed and more thorough irrigation is desired. The irrigation season lasts from June 1 to October 31, the land requiring at most three irrigations per year. In 1905 up to August 1 celery had received one spraying and one irrigation. In dry weather celery is irrigated every two weeks. Twenty-eight thousand plants are raised per acre. It requires twenty-four hours' pumping to spray the 9 acres, two men being employed two days, giving a depth of 0.9 inch.

The cost of the boiler and pump was \$400. Two thousand six hundred feet of 2½-inch pipe used for the distribution of water cost 14 cents per foot. Twelve valves cost \$3 each, and 400 feet of linen 2-inch hose, rubber lined, cost \$160, bringing the total cost of installation to \$960.

Irrigated celery sold at \$1.50 per dozen bunches, each bunch containing 3 to 4 stalks. On unirrigated land in 1905 part of the celery did not mature, and bunches of 6 stalks each sold for \$1.25 per dozen. The value of the crop from the 9-acre farm was \$6,000. The ground was heavily manured in 1905, 60 tons of manure and 1 ton of fertilizer, costing \$45, being used per acre.

No. 15. Mrs. R. C. Shannon, of Northumberland County, irrigates 2¼ acres, 1½ acres of which are planted in celery and the remainder in other truck. Water is pumped from a well dug 60 feet deep and bored 20 feet farther, water standing about 18 feet from the ground. A hot-air engine pumps water into two tanks, each 7 feet in diameter and 8 feet deep, which the pump will fill in six hours. Celery is irrigated every five days in dry weather by the furrow system.

No. 16. W. J. Suter, of Northumberland County, irrigates 2 acres of clay loam with water pumped by a small ram and a windmill. The ram lifts the water 40 feet through 1,200 feet of 1-inch and 1¼-inch pipe, delivering a flow of about 1 gallon per minute. The windmill is 8 feet in diameter and will deliver about one-half this flow. It pumps from a well 4½ feet square dug 26 feet deep. The normal level of the water in the well is 3 feet below the ground. In dry seasons a rate of delivery of 3,000 gallons per day will exhaust the well. The windmill pumps into a tank holding 1,500 gallons, set 20 feet above the ground. The water is distributed by piping and the ground irrigated by a sprinkler, a tankful being sufficient to water one-eighth to one-fourth of an acre. The land is irrigated in dry weather every two weeks, the

season lasting from May to August. Crops never receive more than four irrigations per year.

Labor costs \$1.20 per day and it requires one day to irrigate one-half of an acre, only one-fourth of the time of one man being consumed in moving the sprinkler. The yield per acre of celery brings on an average \$1,600, and of lettuce, of which two crops are raised, \$1,600 for both crops. The value of irrigated land is over \$400 per acre, and of nonirrigated land \$10 to \$100 per acre. The owner estimates that irrigation is worth to him at least \$500 clear gain a year. The cost of the plant was \$450, of which the well cost \$100, the windmill \$100, the pipe \$100, ram and pipe \$50, and labor \$100.

An earth tank built on a hillside for use in irrigation would not hold water, owing to the nature of the soil.

No. 17. C. McWilliams, of Northumberland County, irrigates $1\frac{1}{2}$ acres from a creek. Water is stored in an earth tank with a capacity of 180,000 gallons. Water is taken from the reservoir by a $2\frac{1}{2}$ -inch supply pipe 250 feet long, from which $1\frac{1}{2}$ -inch feeders branch out for the irrigation of the land. Hose is used to supply water to furrows. About 6 feet of head forces the water through the pipes and delivers a flow of 10 gallons per minute, which requires eighteen minutes to flow through a furrow 320 feet long. This rate of flow will irrigate one-half of an acre in twelve hours. The irrigation season lasts from May to the middle of October, the land being irrigated every two to seven days in dry weather.

The value of the yield per acre is \$450. On an average, irrigation increases the value of the crops \$70 an acre. Although 1905 was a wet year, no other property in the vicinity gave as good crops of beets, lettuce, and celery. The value of unirrigated land is \$50 per acre. The owner estimates the value of irrigated land at considerably over \$100 per acre. The total cost of reservoir and plant was \$200.

NEW JERSEY.

The New Jersey Experiment Station at New Brunswick has made many interesting irrigation experiments, the results of which are published in bulletins of this office.^a Water for irrigation is obtained from the city mains and applied by the furrow system, the ground during dry weather being watered every seven days. The usual depth of irrigation is 2 inches. The experience here shows that in humid climates light irrigations are preferable, since a heavy rain following an irrigation is liable to swamp the land.

No. 18. F. W. Kilbourne, of Middlesex County, irrigates 2 acres of truck from the New Brunswick city waterworks at the rate of \$1 per thousand cubic feet. From two to three crops are grown on the same ground, each crop usually receiving one irrigation and

^aU. S. Dept. Agr., Office of Experiment Stations Buls. 36 and 87.

occasionally two. The furrow method of irrigation, with a hose, is employed, the rate of flow from the hose being about $10\frac{1}{2}$ gallons per minute. The furrows are 240 feet long and 3 feet apart, and it requires thirty minutes for the water to run through them, on the average. It requires forty hours to irrigate 1 acre of ground, the cost for water being \$3.30. The soil is a heavy loam 12 inches thick with a red shale gravel subsoil. In 1905 water did not cost over \$25, and the total cost of pipe and hose was only \$25.

Prizetaker onions yielded 900 bushels per acre. Three crops of lettuce of 50,000 plants per acre for each crop are usually grown on the same land, selling wholesale at from 2 to 6 cents a piece. Early cabbage is planted 15 inches apart in rows $2\frac{1}{2}$ feet apart, giving 14,000 heads per acre. One acre of beets yielded 7,000 bunches, bringing 5 cents per bunch. Thirty thousand stalks of celery were planted per acre, yielding 8,000 bunches, 3 to 4 stalks per bunch, selling at 12 cents per bunch. Spinach is seldom watered. Irrigation fully doubles the crop on an average and in 1905 saved the crops from failure.

No. 19. W. P. Stokes, of Burlington County, a florist, formerly irrigated his gardens with a pump driven by a $2\frac{1}{2}$ -horsepower gasoline engine. The water was distributed by pipes and the furrow system of irrigation used. The pump was set in a pit 28 feet deep and obtained its supply from three 2-inch driven wells 53 feet deep. The last few years the rainfall has been ample and the plant has not been used for irrigation. A system of subirrigation has been tried, a line of inverted U-shaped tile being placed on boards about 15 inches below the ground. The soil is so sandy that this was unsuccessful, as the water all sank out of sight before reaching the end of the tiling.

No. 20. Henry A. Dreer, of Burlington County, irrigates 5 acres of land by water pumped from a dug well 8 feet in diameter and 15 feet deep. The well is lined with brick and cost, complete, \$200. The water normally stands 5 feet below the ground level, and it is not lowered more than 1 foot at the highest rate of pumping. A duplex steam pump raises the water from the well into a system of distributing pipes. The pump is provided with an automatic regulator, which, by throttling the steam supply, holds the pressure in the mains constant at 50 pounds, forcing the water into a 3-inch main 700 feet long, from which it is distributed through the field. Horizontal pipes are run parallel to the rows every 50 feet, the length of the pipes being from 250 to 750 feet. These pipes are run about 3 feet above ground and are set on 2 by 4 inch wooden supports 20 feet apart. They are tapped for small brass plugs every 4 feet, the holes for the plugs being all in line. Each of these plugs has a pin hole in the center, which serves as an outlet for the water. The overhead pipe line is connected by a union to the supply pipe in such

a manner that it can be easily turned at any angle. A valve admits water to each pipe. Each line is supposed to water 25 feet on either side, and after one side is watered the pipe is revolved until the streams of water are at the proper angle for watering the other side. The water by the time it reaches the ground is in the form of a fine spray.

The 250-foot lengths of pipe are composed of 100 feet of 1¼-inch pipe, 75 feet of 1-inch, and 75 feet of three-fourths-inch pipe. The 750-foot lengths are composed of 320 feet of 1¼-inch pipe, 240 feet of 1-inch pipe, and 190 feet of three-fourths-inch pipe. The small brass plugs, as well as the special drill provided with spirit level for boring holes in the same so as to have them in line, are both patented. The drill with spirit level sells for \$10 and the brass plugs for 3 cents each. The measured discharge from one brass plug was 0.3 gallon per minute. In normal operation, one line of pipe will irrigate a space 50 feet in width in nine hours' run. This would correspond to a depth of irrigation of 1.3 inches. At its normal rate of operation, the pump is used to supply 9 lines 250 feet in length, or 2,250 feet of pipe, or 2½ acres. This would correspond to a rate of flow from the pump of 169 gallons per minute. If desired, the pump could be run at double this capacity. All pipe in use throughout the plant is galvanized. The well water being clear, no trouble has yet been experienced with the small outlets in the brass plugs stopping up.

The irrigation season lasts from the middle of April to the middle of October. The crops irrigated are flowers and strawberries. In dry weather they receive an irrigation every ten days, but they usually require not more than three irrigations per season. Irrigation is carried on, as a rule, between 7 p. m. and 4 a. m., in order to avoid scalding the crops and baking the ground. From 1.1 acres of irrigated land, where 91,000 plants were set out, 89,600 good potted plants were obtained, and from unirrigated land in former seasons not over 60,000 plants. As the value is \$25 per thousand, this represents a gain of about \$750 from irrigation.

No. 21. T. R. Hunt, of Hunterdon County, irrigates 6 acres planted in celery, strawberries, cabbage, and potatoes. The land was not irrigated in 1905, the pump cylinder having been cracked by freezing. A 3-horsepower gasoline engine drives a double-acting pump, delivering 30 gallons per minute. Water is taken from a pond and elevated 20 feet, the discharge pipe being 2 inches in diameter and 400 feet long. The cost of the engine was \$225 and the cost of the entire plant \$600. One and one-half gallons of gasoline are sufficient to operate the plant for ten hours.

The soil is a clay gravel loam 12 inches in depth, with a clay subsoil. The furrow system of irrigation is used, the furrows being 350 feet long and 3½ feet apart. The furrows are run on a steep grade and

the flow from the pump divided between five furrows, requiring three and one-half hours to run through them. The pump will irrigate one acre in ten hours. Handmade canvas hose is employed for carrying the water down hill, under very light pressure. Muslin 1 yard in width is cut up into three strips, each of which is made into a hose, which is then dipped in a mixture of coal tar and oil. The water is admitted by short hose to the ends of V-shaped wooden troughs, from which it is admitted to the furrows by means of adjustable sliding gates. (See fig. 1.) The troughs are built of 1 by 5 and 1 by 6 inch boards nailed together and provided with 1¼-inch holes. There are three holes in these troughs for every two furrows, the intermediate one being used to supply additional water to either furrow should it be necessary.

Onions are seldom irrigated. In dry weather celery is irrigated every two weeks, receiving, at most, three irrigations per season. Strawberries usually receive one irrigation per season. In 1902 irrigation saved the entire strawberry crop from destruction. In 1905 without irrigation 3 acres of strawberries yielded 22,000 quarts, which sold for \$2,200. In 1903 irrigated strawberries produced a fine crop, while unirrigated berries were a failure. In dry seasons the same thing is true of celery.

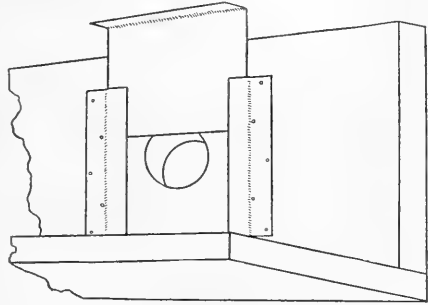

FIG. 1.—Sliding gate in flume.

No. 22. David Astle, of Cumberland County, irrigates 1.6 acres of land from two wells 6 inches and 3 inches in diameter and 47 feet deep, which were bored by a hydraulic process. The 6-inch well cost \$168 and the 3-inch well \$1.35 per foot, or \$62. Surrounding the wells is a brick pit 8 feet in diameter and 16 feet deep, dug at a cost of \$25. The brick walls are laid 4 inches thick, the brick costing \$30. The total cost of the plant was \$1,200. The water stands 23 feet below the ground level, and is hardly lowered by pumping. The water-bearing stratum consists of coarse sand and gravel.

The 6-inch well has a strainer 16 feet long and the 4-inch well a strainer 3 feet long. A 5-horsepower gasoline engine drives, through a countershaft, two double-acting power pumps at 35 revolutions per minute. One of these pumps has the suction side directly connected to the casing of the 3-inch well and the other pump has its suction pipe inside the 6-inch casing. The pumps deliver water into the same discharge pipe, which is 3 inches in diameter and 300 feet in length. The water is raised 44 feet above the ground level

at the pump house into a wooden tank with a capacity of 2,000 gallons. The tank can be filled in thirty minutes. The cost of the tank was \$40 and of the supporting frame \$25. The plant consumes $3\frac{1}{2}$ gallons of gasoline, at $13\frac{1}{2}$ cents per gallon, in a ten hours' run. The water flows back through 300 feet of the supply pipe and then through 800 feet of 2-inch pipe to the land. This 2-inch pipe has an outlet every 22 feet, to which a hose can be connected for supplying a movable pipe with water.

The soil is a light sandy loam 8 inches deep, with a clay and gravel subsoil. The plant will usually irrigate 1 acre in two days' run, or twenty hours. The ground is irrigated by sprinkling from several water

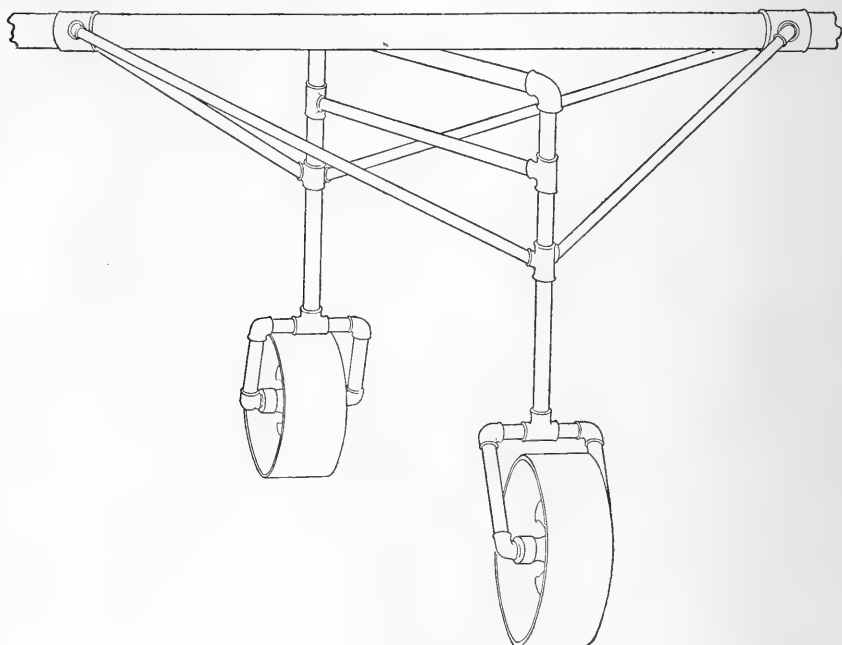

FIG. 2.—Carrier for pipe and sprinklers.

witches set 10 feet apart on a movable length of 2-inch pipe, which is mounted every 20 feet on 2-wheeled carriages. Eleven water witches are mounted on 100 feet of pipe supported by four carriages, as shown in figure 2, and will irrigate, without moving, a space 110 feet by 10 feet. Normally the water witches are run twenty minutes in the same place, but when necessary they are run for as long as an hour. Being mounted on wheels, the apparatus may be easily moved. In the driest seasons it has never been necessary to give the ground more than three thorough irrigations.

The value of the yield from an acre of celery is \$1,200; unirrigated celery in 1903 was a total failure. In 1904 the crop from $1\frac{1}{3}$ acres of

potatoes, irrigated once, brought \$275, and was two weeks ahead of unirrigated potatoes, and, although it was a good year, yielded twice the crop. For one irrigation of potatoes 15 gallons of gasoline, at 13½ cents, were used, and six days' labor, at \$1.50, or a total cost of \$11. In some years irrigation will increase the potato crop fourfold.

No. 23. Cuno Becker, of Cumberland County, formerly irrigated a small tract of land by water pumped from a 2-inch driven well 45 feet deep, the water standing 24 feet below the ground level. A power pump driven by gasoline engine was used to force the water into an elevated wooden tank, which supplied water under 15 pounds pressure to parallel rows of 2-inch pipe running over the land. These rows were 10 feet apart, and on each was mounted a series of thirteen water witches 10 feet apart. Fifteen minutes is sufficient to wet the ground reached at one setting to a depth of 1.6 inches of water. Lawn sprinklers were tried, but required too much labor to move them and too much walking over wet ground. On irrigated land every strawberry ripened, and the berries brought 4 cents per quart more than unirrigated berries, not over half of which matured. Irrigated beets, lettuce, and cabbage were of much finer quality than unirrigated.

No. 24. The State Asylum for Feeble-minded Children, at Vineland, irrigates 10 acres by pumping from wells and 6 acres with sewage. Three 4-inch bored wells 122 to 157 feet deep supply all the water for irrigation and other uses. The wells are provided with 3-inch strainers 10 feet long, and the water stands 20 feet below the ground. A pump raises the water into a 50,000-gallon steel tank set 120 feet above the ground. The normal capacity of the pump is 150 gallons per minute. The boiler plant used for driving the pump is employed for heating in the winter time.

The land is irrigated by the furrow system, the furrows being 400 feet long and 3½ feet apart. The water supply from the tank is led through a pipe to a ditch at the head of the furrows. The plant will irrigate 3½ acres in a half day. The irrigated land will grow two or three crops of truck a year. Fifty thousand gallons of water are used to irrigate 3 acres of land, giving a depth of 0.6 inch. In 1905 irrigated potatoes yielded 271 bushels per acre, receiving but two irrigations, the season being wet. In dry weather the land is irrigated every week. Irrigation will, on the average, add one-third to the potato crop. A man and horse can prepare 6 acres a day for irrigation.

The sewage output of the farm is about 50,000 gallons per day, and is pumped through 250 feet of 4-inch pipe and elevated 6 feet by a 3-inch centrifugal pump driven by a steam engine. It discharges into a cistern holding 20,000 gallons, whence it runs through 500 feet of terra-cotta pipe and is distributed over the land by wild flooding. Only a part of the sewage is at present employed for the irrigation of 3 acres of fruit and 3 acres of beans.

No. 25. William Ash, of Cumberland County, irrigates $3\frac{1}{2}$ acres, one half acre of which is under glass. The water is pumped from a dug well $3\frac{1}{2}$ feet square and 15 feet deep, curbed with wood and brick. The well was sunk at a cost of \$16. Water stands 5 to 13 feet below the surface. A $2\frac{1}{2}$ -horsepower gasoline engine drives two double-acting pumps, which deliver 60 gallons per minute to a line of 2-inch pipe 900 feet long. Three gallons of gasoline, costing 16 cents per gallon, are consumed in a ten hours' run.

The soil is a light sandy loam 10 inches deep, with a sandy clay subsoil. The sprinkling system is used, with four lines of $\frac{3}{4}$ -inch pipe, each of which has three water witches 17 feet apart. The $\frac{3}{4}$ -inch pipes are set in the field from 14 to 18 feet apart and are connected to a 2-inch main by not to exceed 60 feet of $\frac{1}{2}$ -inch hose. Normally the sprinklers run for one-half hour in a place, though sometimes an hour. The plant will irrigate $1\frac{1}{4}$ acres in a twelve hours' run, during which it will take about one-fourth of a man's time to attend to the irrigation and move the pipes. The cost of labor is \$1.50 per day. The maximum lift against which the pump operates is 18 feet. The total cost of the plant was \$700, the engine costing \$150.

From two to three crops are grown on the same land, the spring crops consisting mainly of cauliflower, radishes, beets, and cabbage, and the fall crop of lettuce. Irrigation will fully double the crop in average seasons. The following table shows the yield of the various crops and the frequency of irrigation:

Irrigated crops near Vineland, N. J.

Crop.	Yield per acre.	Rate.	Value.	Maximum irrigations per crop.	Irrigation season.
Beets.....bunches..	20,000	$3\frac{1}{2}$ cents per bunch.	\$700	3	May 20 to June 20.
Cabbage.....heads..	12,000	\$1 per barrel.	350	4	Do.
Cauliflower.....do....	12,000	\$1.50 per barrel.	750	6	May 20 to July 1.
Radishes.....bunches..	20,000	5 cents per bunch.	1,000	2	
Lettuce.....heads..	51,000	1,000	6	Aug. 15 to Oct. 1.

In the driest weather crops are irrigated not more than twice a week, sprinklers being allowed to run for one hour in the same place. Five hundred and fifty bushels of potatoes were raised on an acre of good rich irrigated truck land and 300 bushels on an acre of poorer soil. One acre of unirrigated land, the soil of which was better than the second plat of irrigated potatoes, yielded 90 bushels.

No. 26. George Mitchell, of Cumberland County, has an irrigation plant of sufficient capacity to irrigate 10 acres of truck land. The water comes from a small creek near the farm, across which a small dam has been erected. In dry weather, when the supply from the creek is insufficient, the storage afforded by the dam will supply the pump for

three hours. A $2\frac{1}{2}$ -horsepower gasoline engine drives a No. 2 centrifugal pump delivering 110 gallons per minute against a total lift of 15 feet. The discharge pipe is 4 inches in diameter and 500 feet long. The engine consumes 3 gallons of gasoline in ten hours.

The furrow system of irrigation is employed, the furrows being 4 feet apart and 600 feet or less in length, set on a grade of 1 foot per 100 feet. The entire supply is usually turned into two furrows, requiring fifteen minutes to run through. One man can irrigate an acre in four hours. The cost of labor is \$1.25 per day. The owner estimates that the cost per acre for fuel and labor is \$1 for each irrigation, the depth applied being $\frac{1}{2}$ to $1\frac{1}{2}$ inches.

Sweet corn is irrigated if dry at the time the ears are setting, or if needed, while the ears are growing. In a good year unirrigated sweet potatoes will yield from 100 to 300 bushels per acre. They are commonly planted May 20 and harvested in October. September is the most important season for the irrigation of sweet potatoes, a single irrigation in September having increased the value of the sweet potato crop \$40 per acre.

No. 27. J. H. Shute, of Gloucester County, irrigates 1 acre of land, planted in truck and strawberries, with water pumped from a $1\frac{1}{4}$ -inch driven well 25 feet deep, provided with a strainer $4\frac{1}{2}$ feet long. The cost of the well was \$14. The water stands 14 feet below the ground level. A hot-air engine drives a double-acting pump, which lifts the water into a wooden tank 31 feet above the ground. The tank holds 2,000 gallons and the pump will fill it in seven hours. An 8-foot windmill is also used for pumping from the same well. The hot-air engine uses kerosene for fuel, at a cost of 7 cents per gallon. In a ten hours' run the engine consumes 2 gallons of kerosene.

The soil is a dark waxy loam 12 inches deep, with a clayey gravel subsoil. The furrow system of irrigation is employed, water being supplied to the furrows through a hose. The furrows are 100 feet long and 3 feet apart. Water is furnished to the field through $1\frac{1}{4}$ -inch and $\frac{3}{4}$ -inch pipes. The irrigation of an acre of ground will usually require 6 tanks of water, giving a depth of 0.35 inch. It requires two days to irrigate 1 acre. The cost of the plant was \$455, of which the engine cost \$130, the windmill and pump \$125, the tank \$150, and the pipe \$50.

Celery is irrigated twice a week in the driest weather, receiving at most 15 irrigations per year. Onions are irrigated every two to three days and yield 600 bushels per acre. In 1903 the crop from one-third of an acre brought \$250 and would have failed without irrigation. On the same land during the same year 60 barrels of onions, at \$2.40 per barrel, had previously been raised, making \$394 from one-third of an acre of land.

No. 28. L. M. Parkhurst, of Atlantic County, irrigates 3 acres from a 3-inch bored well 50 feet deep. The well is provided with a 6-foot strainer, and the water stratum is gravel. The water stands 23 feet below the surface. The cost of the well was \$50. A No. 8 hot-air engine drives a pump delivering 8.3 gallons per minute. The total lift of the water is approximately 26 feet. The fuel used by the engine is kerosene, purchased at $9\frac{1}{2}$ cents per gallon, and in twenty hours' run the fuel consumption is 7 gallons. The plant cost \$350 and used 5 barrels of kerosene in 1905. Water is pumped into an earth reservoir 22 feet square on top and 4 feet deep, lined with 1-to-1. cement 1 inch thick. The construction of the reservoir required one foreman, two field hands, and one team for four days, making a labor cost of about \$25. It is fairly tight, though the lining is cracked in a few places.

The furrow system of irrigation is commonly used, though occasionally land is watered by hose. The furrows are 400 feet long and 4 feet apart. The discharge from the reservoir is turned down one furrow, through which it flows in about thirty minutes. It requires five hours to irrigate one-half an acre, using one reservoir full, or a depth of about 0.9 inch.

The ground is a black waxy loam 7 inches deep, with a gravel subsoil. The ground is irrigated in dry weather once or twice a week. Strawberries receive at most three irrigations. Two acres in strawberries yielded in 1905 4,000 quarts per acre, while unirrigated land yielded but 2,800 quarts per acre. Potatoes, which received one irrigation in 1905 rather late in the season, yielded one-fourth larger crop than unirrigated potatoes. Irrigation will in general increase the yield from one-third to one-half.

No. 29. Herman Graumann, of Atlantic County, irrigates 10 acres planted to strawberries and truck, from three $2\frac{1}{2}$ -inch driven wells 22 feet deep, the water level in which is 16 feet below the ground. The wells, which are located far apart, cost \$15 each to drive and are pumped by means of a portable $2\frac{1}{2}$ -horsepower gasoline engine, which drives a double-acting power pump, delivering 33 gallons per minute. The pump and engine, which are mounted on the same truck, are hauled from well to well, as required, and the water discharges through a $3\frac{1}{2}$ -inch canvas hose from 50 to 1,000 feet in length, whence it is distributed over the land by spraying. The pump will irrigate one acre in four hours.

The soil is a sandy and waxy loam 12 inches deep with a gravelly clay subsoil. Truck is irrigated every seven days; strawberries every one or two days in the driest weather. Strawberries are watered by furrows 80 feet long and 4 feet apart, and it takes the water twelve minutes to flow through. Two men are required to operate the pump and distribute the water. Irrigation in dry years increases the return

from strawberries at least \$100 per acre. The plant cost \$270, of which the engine cost \$200, the pump \$60, and the truck \$10. The hose is a second-hand fire hose and cost the owner nothing.

The cost of well boring in this vicinity is as follows:

	Per foot.
1½-inch well.....	\$0. 50
2-inch well.....	. 75
3-inch well.....	1. 50-1. 75

No. 30. John I. Sickles, of Monmouth County, irrigates 6 acres in truck and strawberries with water pumped from a brook by an 8-foot windmill mounted on a 50-foot tower. Water is pumped through 14 feet of 1½-inch pipe and elevated 30 feet to a tank holding 6,000 gallons. A 1½-inch main with branches of ¾-inch pipe 200 feet long and 75 feet apart, provided with taps for ¾-inch hose, distributes water over the land. The cost of the entire system was \$1,600.

The soil is a light sandy loam. The land is irrigated by sprinkling. The water witches used will cover a circle 20 feet in diameter and are allowed to run for twenty-five minutes in the same place. Strawberries are irrigated at night by the furrow system and in dry weather are watered every night. Truck is irrigated in dry weather every one or two days, the irrigation season lasting from March to October.

By the aid of irrigation three crops can be grown on the land. In 1905 three crops were grown on unirrigated land, but average years yield about a crop and a half. Irrigation increases the yield of strawberries and peas 50 per cent and matures radishes ten days earlier. Beets were two weeks earlier when irrigated. The results with cabbage were not good, probably owing to the ground being insufficiently tilled. In very dry weather radishes were raised by irrigation in twenty-one days from the time of planting.

No. 31. Julius Roehrs, of Bergen County, has an extensive system of hothouses irrigated with water from the city mains at a cost of \$1.40 per thousand cubic feet.

No. 32. William Young, of Essex County, irrigates 12 acres of truck with water pumped from an 8-inch well 406 feet deep, which cost \$2.50 a foot. The water stands 24 feet below the ground and is lowered 2 feet when the pump is in use. A vertical 15-horsepower boiler supplies steam under 65 pounds pressure to a direct-acting steam pump, with 2½-inch suction and 2-inch discharge, delivering 65 gallons per minute. The vertical lift is 30 feet. The fuel is soft coal, costing \$4.25 per ton, about 30 tons being used in one year. The plant is usually operated for twelve to fifteen hours a day. Five thousand feet of 2-inch pipe are used in distributing the water over the farm. Several lengths are coupled together with unions 40 feet apart. Every 20 feet is a T, from which a half-inch pipe 6 feet long rises vertically, on top of which is a water witch. The line of sprinklers is connected by

a hose to 2-inch mains running through the farm. These mains are taken up in winter. The pump will operate twenty-one water witches, which are run for an hour and a half in one place for a thorough irrigation, after which the pipe is moved in sections a distance of 25 feet. It takes three men fifteen minutes to move and set up a line of twenty-one sprinklers.

The soil is of a black waxy consistency 1 foot deep, with a clay subsoil. It requires one hundred hours to irrigate 12 acres. In dry weather truck is irrigated every week. The crops grown consist of celery, cabbage, cauliflower, beets, and radishes. Two crops a year are usually grown.

No. 33. F. J. Forthuber, of Essex County, irrigates 15 acres by pumping from a creek. A 20-horsepower vertical boiler supplies steam under 70 pounds pressure to a duplex steam pump with a 4-inch suction pipe 50 feet long and a 3-inch discharge pipe 1,200 feet long, with outlets 50 to 100 feet apart. The vertical lift is 70 feet, but the water pressure usually carried at the pump station is 70 to 100 pounds. Hard nut coal, at a cost of \$4.25 per ton, is used for fuel, the consumption being 500 pounds in ten hours. The annual consumption is 6 to 12 tons. Water witches are mounted on $\frac{3}{4}$ -inch pipe rising vertically from a $1\frac{1}{2}$ -inch pipe line. The water-witch line is connected with unions every three lengths (60 feet). The pump supplies twenty water witches, which are spaced 20 feet apart, and it takes three men fifteen minutes to move a line of twenty. If the land is very dry they are run in the same place for an hour. This irrigation is repeated the next day, and after that once or twice a week. The pump delivers 150 gallons per minute and will irrigate 1 acre in ten hours, giving a depth of about 3.5 inches.

Lettuce, celery, and other kinds of truck are irrigated not over six times per crop, starting in May. Celery and lettuce are the crops most improved by irrigation.

The total cost of the plant was \$2,000, and the owner estimates that in 1902 irrigation increased the value of the crops \$1,000. For the last two years it has been of no material benefit and is said to do considerable harm when followed by heavy rains.

No. 34. Henry Schumacher, of Morris County, irrigates 10 acres of truck from the city waterworks, paying \$1.50 per thousand cubic feet. A $1\frac{1}{4}$ -inch main is run through the farm for a distance of 600 feet, with taps 100 feet apart. Six water witches on half-inch pipe are mounted 15 feet apart on a section of $1\frac{1}{4}$ -inch pipe. With the usual pressure they will irrigate a space 15 feet wide. Three men are required to move the line of witches, which are run one-half hour to an hour in the same place. Eight hundred feet of $\frac{3}{4}$ -inch hose, costing 8 cents a foot, is used, in lengths of 200 feet or less. The

pipe laid in the ground cost \$100, the water witches, etc., \$25, and the hose \$64, making the total cost \$189.

The soil is a dark loam 12 inches deep, with clay subsoil. One acre can be irrigated in twenty hours with six sprinklers, one set of sprinklers being run at a time. It takes one day's labor at \$1.25 to irrigate an acre of land. Crops are irrigated in dry weather every two weeks, receiving at most three irrigations in a season. Water is not applied in the heat of the day, but usually at night.

The average cost of water is \$100 per year. The price of land in this vicinity is high, due largely to its speculative value. Two crops are grown in a season. Irrigation sometimes saves the entire crop from failure, and the owner estimates that the value of the crops, which averages \$1,000 per acre, is increased 40 per cent by irrigation, which insures better quality and earlier crops.

No. 36. Arthur Robinson, of Hudson County, irrigates 2 acres from the city waterworks, paying \$1.50 per thousand cubic feet. Three water witches 9 feet apart, connected together by a hose, are mounted on a wooden frame 18 feet long provided with two runners, so that it can be easily dragged about. This is fed by a $\frac{3}{4}$ -inch hose connected to a 1-inch main running through the farm. The water witches irrigate a space 10 feet wide and run twenty or thirty minutes in the same place. One man can easily move them. They use 1,000 cubic feet in a twelve-hour run. The owner estimates that irrigation doubles the yield in average seasons. Celery and cauliflower are watered once a week in very dry weather.

No. 37. W. Gurnheit, of Hudson County, irrigates 15 acres in truck with water from the Hackenside Water Company, at a cost of \$1.40 per thousand cubic feet. A 2-inch main runs through the farm, provided with 1-inch branches every 100 feet. These branches are provided with $\frac{3}{4}$ -inch valves every 20 feet. Four sprinklers, mounted on vertical pipes 10 feet apart, extending upward from the $\frac{3}{4}$ -inch pipe, are operated at the same time. These will irrigate a space 10 feet wide. They are usually run for an hour in the same place. Three-quarter-inch hose, in lengths up to 150 feet, is used to connect the pipe line with the water-witch line. In dry weather the crops are watered once a week. The annual cost of water is about \$150. Radishes are not so sensitive to overirrigation as spinach, lettuce, and beets.

There are about 50 irrigated farms in the vicinity of Seacaucus using similar methods of irrigation. Nearly all obtain water from the same company.

NEW YORK.

No. 38. F. Schumacher, of Queens County, irrigates 15 acres of truck from a spring. The supply is reinforced by three 2-inch driven wells 40 feet deep, in which the water rises and flows into the spring.

The pipe for the wells cost 15 cents a foot, and the cost of driving the three wells was \$5. A 4-horsepower vertical boiler supplies steam at 40 pounds to a duplex pump, which delivers 75 gallons per minute through 1,200 feet of 2-inch pipe, against a 60-foot vertical lift into a wooden tank holding 12,000 gallons. The fuel used is hard coal, costing \$6 per ton, 5 to 8 tons being used in a season. In a twelve-hour run 250 pounds of coal is burned. One man is required for the operation of the steam plant. A 10-foot windmill, supplied from a 2-inch well, is also used to pump water into the tank. It pumps against a total lift of 75 feet.

The soil is a light sandy loam, 12 inches deep, with a clay subsoil. Sprinkling from water witches is usually employed, although occasionally furrow irrigation is used. The water supply will irrigate 1 acre in eighteen hours. The water witches are mounted on $\frac{3}{4}$ -inch pipe 3 feet high, which rise vertically every 10 feet from T's on a 1-inch pipe, which is 190 feet long, making twenty water witches on the line of 1-inch pipe. The sprinklers are run for half an hour or more in one place and will irrigate a strip 10 to 14 feet wide. The entire sprinkler pipe line is moved by six men in one minute. Thirty-five hundred feet of 2-inch pipe and 500 feet of inch hose are used in distributing water over the farm. The cost of the entire plant was \$1,500. The 2-inch hose cost 11 cents per foot and the tank \$95.

In dry weather most truck is irrigated every week. Lettuce is irrigated every two to three weeks. The owner believes that irrigation is worth \$1,000 in average years. In one year the crop from a single acre of irrigated lettuce sold for \$1,000, while unirrigated lettuce failed entirely. Potatoes and onions are seldom irrigated.

No. 39. Phillip Bach, of Queens County, irrigates 7 acres in truck from five 2-inch driven wells, 20 feet deep, costing \$28 apiece. The water stands 10 feet below the surface. A vertical boiler supplies steam to a duplex pump, delivering 80 gallons per minute, against a vertical lift of 67 feet, through 1,200 feet of 2-inch pipe into a wooden reservoir holding 10,000 gallons. A 12-foot windmill furnishes an additional supply. The pump will fill the tank in two hours. Four hundred pounds of hard coal, costing \$5 a ton, is used in a ten-hour run.

The soil is a sandy loam, 3 feet deep, with a clay subsoil. The pump will irrigate 1 acre in ten hours. The water is distributed over the farm through a 2-inch main with $1\frac{1}{4}$ -inch branches 150 feet apart. These branches are provided with 1-inch outlets 75 feet apart, to which a series of water witches is connected by hose. The water-witch lines, three of which are used at a time, consist of 6 sprinklers, each mounted on $\frac{3}{8}$ -inch pipe, which rise vertically every 12 feet from a 1-inch pipe. The water witches will irrigate an area 14 feet wide. Three men can move the water-witch line in two minutes. Not over

50 feet of hose is employed in making the connection from the pipe line. In ordinary irrigation the water witches will run in the same place for one-half to three-quarters of an hour. In dry weather crops are irrigated every week, receiving not over twelve irrigations in a season. Three thousand feet of 2-inch pipe is used. Two to four crops are commonly grown on the same land. The total cost of the plant was \$1,200.

No. 40. Witte Brothers, of Queens County, irrigate 18 acres from a 6-inch well, 88 feet deep, provided with a 3-foot strainer. The water-bearing stratum is sand. The water stands 18 feet below the surface and is lowered to 36 feet by pumping. The cost of the well was \$380. A 4-horsepower vertical boiler supplies steam at 20 pounds to a deep-well pump set vertically over the well. The total lift of the water is 61 feet. Hard coal, costing \$6 a ton, is used for fuel, the annual consumption being 10 tons. In fifteen hours the plant burns 4 bushels, or 325 pounds of coal.

The soil is a sandy and waxy loam 12 inches deep, with a clay subsoil. The main for distributing the water is a 2-inch pipe with 1-inch outlets. Both hose and water witches are used. Four water witches mounted on $\frac{1}{2}$ -inch vertical pipes are supplied by a 1-inch pipe line. It requires two men to move the sprinkler pipe line. The water witches are 14 feet apart and water a tract 14 feet wide. They are run in the same place $1\frac{1}{2}$ hours. The pump will operate eight sprinklers and one 1-inch hose, and will in addition fill the tank in fifteen hours.

Cauliflower and cabbage are usually watered with the hose every three days in dry weather. Lettuce and celery are sprinkled once a week. The hose will water one acre in five hours, using about as much water as five sprinklers. The distance from the tank to the power house is 1,000 feet. The plant contains 2,800 feet of 2-inch pipe and cost \$2,500.

No. 41. B. H. Mohlenhoff, of Queens County, irrigates 3 acres with city water. The price charged for water for this and adjacent plants is \$3 for the first thousand cubic feet, \$2 for the second, and \$1 per thousand for all additional water used within six months. A $1\frac{1}{2}$ -inch main provided with $\frac{3}{4}$ -inch valves is run through the farm. Three or four water witches 18 feet apart are attached to one section of 1-inch pipe by $\frac{3}{8}$ -inch vertical pipes and will irrigate a space 18 feet wide. They are usually run in one place for three-quarters of an hour. Not over 200 feet of hose is employed. Three men are required to handle the water-witch line. In dry weather the land is irrigated every week. The water is considered rather cold for irrigation, and the pressure is considered too low for the sprinklers.

No. 42. August Plenge, of Queens County, irrigates 4 acres with city water. Five water sprinklers are operated from a 1-inch water-witch line. The water witches are mounted on $\frac{3}{8}$ -inch vertical pipes 8 feet

apart and will irrigate a space 9 feet wide. They run one-half hour to an hour in the same place, and it requires three men to move the line. Three-quarter inch hose in lengths up to 300 feet is employed to feed the water-witch line. Two-inch and $1\frac{1}{2}$ -inch pipe, provided with 1-inch valves 30 feet apart, supply the farm.

The soil is a light sandy and waxy loam 7 inches deep and is inclined to bake after irrigation. Truck is irrigated every week in dry weather. The total cost of the plant was \$400. The annual cost of water is \$100. Irrigation has paid well, and in 1905 was particularly useful in starting crops.

No. 43. John Schumacher, of Queens County, irrigates 4 acres of truck from the city waterworks. Five water witches are mounted on $\frac{3}{8}$ -inch vertical pipes connected to a $1\frac{1}{4}$ -inch water-witch line, which it requires four men to handle. The water witches are 16 feet apart and water a tract 16 feet wide. They run from thirty minutes to an hour in the same place. The main is 2-inch pipe with $1\frac{1}{4}$ -inch branches. The total cost of the plant was \$750, and the annual cost of water is \$100. The value of the land in this vicinity is \$1,000 per acre.

Truck is irrigated not more than twice a week in the driest weather. Irrigation doubles the value of the crops in average seasons. Two to three crops per year are commonly raised on the same land, and in dry seasons irrigated land can grow one crop more than the land not irrigated.

No. 44. Bender Brothers, of Queens County, irrigate 17 acres of truck with water from the pipe line of the Bowery Bay Improvement Company, at a cost of \$1 per 1,000 cubic feet. Five sprinklers mounted 16 feet apart on $\frac{3}{8}$ -inch vertical pipes are usually operated from the same line. Three to four lines are operated on the farm, requiring four men to move them. The water witches irrigate a space 16 feet wide and run on the same piece of land from one-half hour to an hour. They are supplied through a 1-inch connection and a $\frac{3}{4}$ -inch valve, the water supply being under 80 pounds pressure. Twenty-five hundred feet of 2-inch main is employed in distributing the water over the farm, and $\frac{3}{4}$ -inch hose is employed in lengths up to 600 feet. The land is irrigated every week or two in dry weather.

The total cost of the plant including the meter was \$830, of which \$150 is for hose. The annual cost of water on the farm is \$125. As a rule water is applied from the latter part of the afternoon until midnight. The owner says that irrigation doubles the value of hotbed crops—lettuce and soup greens. The plant will irrigate 12 acres of land in six days. Labor costs \$1 to \$1.25 per day, and \$18 to \$20 per month, with board.

MASSACHUSETTS.

No. 45. The largest irrigated farms investigated were in the vicinity of Boston. Frank Coolidge, of Middlesex County, irrigates 100 acres of truck land with water pumped from several open bottom wells $2\frac{1}{2}$ to 4 inches in diameter and 20 to 30 feet deep. The water in the wells stands 9 feet below the surface and is lowered 2 feet when pumping at full capacity. The boiler plant, which is used for heating in the winter, consists of three 14-foot horizontal boilers, supplying steam at 90 pounds to two direct-acting steam pumps. Water is delivered at a pressure of 85 to 100 pounds. The plant uses $2\frac{1}{2}$ tons of soft coal in ten hours, one man attending to the plant. The plant is usually operated from 7 a. m. to 6 p. m., although occasionally when the weather is very dry it is run twenty-four hours.

One and one-fourth inch rubber hose is used in lengths of 100 feet, with fan-shaped nozzles. The combined capacity of the pumps is sufficient for 8 nozzles. The hose is fed through $1\frac{1}{4}$ -inch valves placed every 60 feet in the distributing pipe. The piping is all laid on top of the ground and is taken up in the winter. The distributing pipe where it leaves the pumping station is 4 inches in diameter, and it reduces in size at various parts of the farm down to $1\frac{1}{4}$ inches. The large pump is sufficient to supply five hose streams and the smaller pump three.

The soil consists of a light sandy loam 10 inches deep, with a sandy subsoil. One man with a hose can irrigate 0.9 acre in a day. Occasionally water is distributed in furrows, the quantity of water used being twice as great as when the hose is used. The furrows are 50 to 150 feet long, averaging 6 feet apart. Two to four crops are usually grown on the same land in a year, and sometimes five. Irrigation sometimes saves the loss of an entire crop. The cost of the plant was about \$7,000.

No. 46. W. W. Rawson, of Middlesex County, irrigates 40 acres by pumping from 4-inch open bottom wells 85 feet deep. Three pumping stations have been installed for supplying water, in each of which is a 4-inch well and a 48-inch by 13-foot horizontal boiler, which supplies steam under 60 pounds pressure to a steam pump. The well water stands 10 feet below the ground and is lowered 6 feet when the pumps are operated at 50 strokes per minute, delivering 55 gallons per minute each. The maximum total lift is 40 feet. The water flows through 1,000 feet of 4-inch and 1,000 feet of 3-inch main pipe. The laterals used are $2\frac{1}{2}$ inch and $1\frac{1}{4}$ -inch pipe. Each plant consumes 1 ton of soft coal at \$4, in a twelve-hour run. Forty to 50 tons are burned in the three plants in a season. The cost of labor is \$1.75 per day. The total cost of the plant was \$3,000. The hose sprinkling system is usually employed. Sometimes the furrow system is used, each pump supplying two $2\frac{1}{2}$ -inch hose streams. Two hundred gallons per

minute will furnish four hose streams, each of which will irrigate an acre in a day.

The soil is a sandy loam 2 feet deep, with a sandy subsoil. The ground is irrigated in dry weather every week to a depth of 1 inch. City water, costing \$1.10 per 1,000 cubic feet, was used to the extent of \$1,000 in 1905 instead of pumped water. It is often impossible to raise crops without water. On the average irrigation will increase the yield one-third.

No. 47. Weyman Brothers, of Middlesex County, irrigate 40 acres of land with water pumped from a dug well 10 feet deep, in which the water stands 5 feet below the level of the ground. The land is located near a lake, and the water level in the well is not lowered appreciably by pumping. A 25-horsepower horizontal boiler furnishes steam to a duplex pump, which is run at 75 strokes per minute. Soft coal, costing \$4.50 per ton, is used. The plant consumes one-half ton in ten hours.

The pump delivers water either into a reservoir or direct into the mains. The reservoir is 40 feet in diameter and 11 feet deep, built of stone with cement-lined walls, and fills in seven hours. The reservoir gives a pressure at the farm of 15 pounds per square inch. When pumping direct into the mains the pump will supply twelve 1-inch hose streams through a 4-inch main 450 feet long. Movable branches of 2½-inch pipe, provided with outlets 56 feet apart, may be attached every hundred feet. One-inch hose distributes water from these outlets, the greatest length of hose employed being 150 feet.

The present plant is suitable for about 20 acres and is being enlarged. The plant is operated about thirteen hours a day and supplies the reservoir twice a week. The land is watered every three days in the driest weather. Furrow irrigation is used to a limited extent. The owner values irrigation as an insurance and says it doubles the crop at times and sometimes increases it only a third.

No. 48. James Purcell, of Middlesex County, irrigates 10 acres from the city waterworks. The main consists of 2-inch and 1¼-inch pipe, from which branches of 1-inch and 1¼-inch pipe run out 100 feet apart, provided with outlets every 100 feet for 1-inch hose used in lengths of 50 feet.

The soil and subsoil are sandy, and one stream of water will irrigate one-half acre in a day. Truck is watered every week in dry weather. The annual cost of water for irrigation is \$100.

No. 49. W. H. Allen, of Middlesex County, has several farms near Arlington irrigated by pumping and from the city mains. One farm of 15 acres is irrigated by city water at \$1.10 per thousand cubic feet, or about \$400 annually. The method of irrigation was mainly sprinkling by hose. Where the furrow system is used the furrows are 300 feet long. The soil is all sandy. One stream of water will irrigate

one-half acre in a day. Three to four streams at a time are used on this farm.

For another farm of 35 acres water is obtained by pumping from a well. A steam pump delivers water against a 15-foot lift, through 2½-inch pipes. This plant burns 800 pounds of coal in twelve hours. Seven men are employed on this farm, one man for running the pumping station and six for watering the land. Irrigation doubles the yield of eggplant and almost doubles the yield of other crops. Without irrigation it would be impossible to raise celery.

On a third farm 45 acres of land are irrigated by pumping and from the city mains. A 15-horsepower vertical boiler supplies steam to a duplex pump, which delivers water into the main under 70 pounds pressure. The plant uses 700 pounds of soft coal in twelve hours. This plant supplies four hose streams and the city waterworks three, the cost of city water being 75 cents per thousand cubic feet. At times fifteen men are employed in the irrigation of this farm, the work being carried on day and night.

When the land is irrigated by sprinkling, which is the usual method, one man will irrigate one-half acre in a day. The water issues from the sprinkler in the form of a cone, the sprinkler being provided with an adjustable cone plug in the center for varying the size of the opening, as shown in figure 3. Part of the land is irrigated by the furrow system, using 2 to 2½ inch streams of water. One man operates each stream, irrigating an acre in a day.

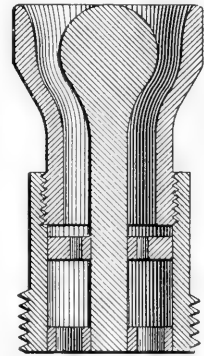

FIG. 3.—Adjustable nozzle.

No. 50. The Hittinger Fruit Company, of Suffolk County, formerly irrigated several acres from a hillside spring. A 150,000-gallon brick and cement-lined reservoir was supplied from an 8-inch bored well 254 feet deep, cased 45 feet. The water stands 6 feet below the ground, but when pumping 40 gallons per minute it is lowered 150 feet. Overhead revolving sprinklers were formerly used for distributing the water; but as there was considerable trouble from the holes stopping up from rust, the system was given up. A ground line of 1½-inch pipe was connected every 30 feet with 1¼-inch vertical pipes, each having a 1-inch horizontal pipe attached.

A more satisfactory arrangement, made of 2-inch pipe, is shown in figure 4. It is provided at the end with connection for a 2-inch hose, to which is attached a one-half to five-eighths inch nozzle. The horizontal pipe was 20 feet long and was provided with a counter-balance and a swivel to turn about the vertical pipe. The pipes were spaced 150 feet apart, and this arrangement was found quite satisfactory. One day's labor was required to irrigate 1 acre. The

furrow system was used for strawberries, the furrows being 150 feet long and 3 feet apart. One hundred feet of 2-inch hose was employed for this purpose. In a dry year the strawberry crop was doubled. The greater part of the farm is now devoted to fruit trees, and irrigation has been practically abandoned.

No. 51. C. H. Slade, of Suffolk County, irrigates 10 acres by pumping from a dug well 15 feet deep, the water standing 6 feet below the ground. A boiler, which in cold weather heats a greenhouse, furnishes steam to a direct-acting pump which delivers water against a 75-foot lift into a 10,000-gallon wooden tank, which it fills in eight hours. The water for the tank is pumped through 500 feet of 2-inch pipe. The hose system of irrigation is used. A $\frac{3}{4}$ -inch hose will empty the tank in ten hours, and in this time will irrigate 1 acre of land to a depth of 0.4 inch. The water is used largely in greenhouse

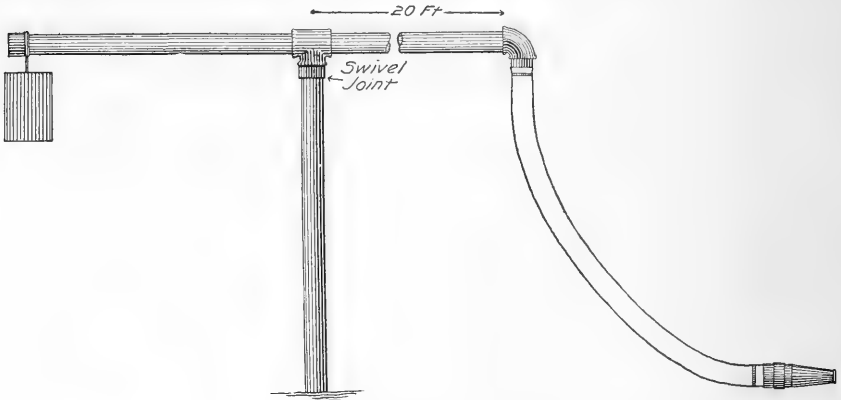

FIG. 4.—Adjustable hydrant with hose and nozzle.

irrigation, a hose and sprinkler being employed. Cucumbers are irrigated every day in dry weather. This plant cost \$1,000, including tower and tank.

The same owner irrigates 12 acres by pumping directly into a 3-inch pipe line, provided with T's for hose connection every 300 feet. The pump will supply a 2-inch hose stream. Hose is used in lengths up to 300 feet and the water is distributed by sprinkling. This plant cost \$600, and uses $\frac{1}{2}$ ton of coal, at \$4.50, in a day. In 1905, 5 acres were irrigated. The pump will irrigate 1 acre in two days to a depth of 4.5 inches. The great difference in the depth required inside a greenhouse and in the field shows very clearly the effect of the glass cover in preventing evaporation.

No. 52. A. H. Long, of Suffolk County, irrigates 1 acre with city water, costing \$1.20 per thousand cubic feet. The water is distributed by sprinkling from a single water witch, the annual cost of water

being \$100. The sprinkler will cover a 20-foot circle, and is run for half an hour in the same place. The owner estimates that in 1905 irrigation was worth at least \$200 an acre to him, increasing the yield about one-third.

On a farm near by 5 acres were formerly irrigated by pumping from four driven wells 2 inches in diameter and 20 feet deep. The cost of the plant, which consisted of a 25-horsepower boiler and a No. 6 pump, delivering 28 gallons per minute, was \$500. Five hundred pounds of soft coal, at \$4.50, were used in twelve hours. The water was supplied to the farm through 500 feet of 3-inch pipe and 100 feet of 2½-inch fire hose, the full flow requiring twelve hours to water an acre to a depth of 0.7 inch. The annual cost of fuel and labor for operating the plant was \$250. The cost of labor is \$1.50 per day.

No. 53. H. W. Locke, of Middlesex County, irrigates 10 acres of celery and cabbage from the city waterworks. A 1½-inch main pipe distributes the water under 25 pounds pressure to ¾-inch hose. The pipe is run on top of the ground and moved as desired. One man can water an acre in a day. As a rule irrigation is used only for planting and shortly afterwards, although occasionally four or five irrigations are applied. The cost of water averages \$75 a year. Irrigation frequently saves the crop.

No. 54. Lovell Brothers, of Middlesex County, irrigated 2 acres of celery for the first time in 1905, using water from the Metropolitan Water Company, at the factory rate of 20 cents per thousand cubic feet. The water is distributed by means of ¾-inch hose. The soil is clay and does not require so much moisture as the sandy soil of surrounding farms. The land was irrigated for planting only. One man irrigated half an acre a day.

No. 55. Pierce Brothers, of Middlesex County, irrigate 6 acres from the city waterworks, using a 1¼-inch main, provided with outlets every 75 feet for ¾-inch hose. The furrow system is also used occasionally, the furrows being 300 feet long and 6 feet apart. The flow from the hose will irrigate one furrow in an hour.

The soil and subsoil are a gravelly loam. Crops are irrigated every three or four days in dry weather, each crop receiving from five to ten irrigations. From one to three crops are grown on the same ground. In a dry season it would be impossible to grow crops without irrigation, and in average seasons irrigation increases the yield of the land fully 25 per cent. The cost of water is \$100 per year.

No. 56. James W. Russell, of Middlesex County, irrigates one farm at Winchester and another near Medford. On the first farm 5 acres are irrigated with city water, costing \$1.50 per thousand cubic feet, with a discount of 50 per cent for every 1,000,000 gallons (134,000 cubic feet) used in a year. In 1904 and 1905, 5 acres were irrigated. The cost of water in 1904 was \$60 and in 1905 \$30.

Spinach, lettuce, corn, celery, and cauliflower are the crops irrigated. The town pressure is insufficient for the use of sprinklers, so the furrow system is used. The cost of irrigation equipment on the farm was \$300. In dry seasons irrigation increases the yield from 20 to 50 per cent.

On the second farm 21 acres are irrigated from a pond, partly fed by two 2½-inch wells 50 feet deep, which flow when the pond is lowered by pumping. A portable 10-horsepower boiler and a direct acting steam pump are mounted on a wagon. At 90 strokes per minute the pump delivers 180 gallons per minute through 400 feet of 3-inch pipe, and through 2½-inch fire hose in lengths up to 1,200 feet. Rubber-lined canvas hose costs \$1 per foot and lasts 10 years. The plant cost \$1,700.

The furrow system of irrigation is commonly used, the furrows being 210 to 400 feet long and 4 to 5 feet apart. The stream from a 2½-inch hose is divided between 5 to 20 furrows, according to the grade of the land, the usual number being 7, in which event it requires twenty minutes to irrigate them. Four acres can be irrigated in an eleven-hour run. One man distributes the water, but it requires three men once a day to move the pipe. Bare land is irrigated for planting by attaching a 1-inch nozzle to the hose. Tender plants are watered with a ½-inch nozzle under high pressure, which makes a fine spray.

The soil is a sandy loam 7 to 12 inches deep, with a gravel and sand subsoil. The average lift does not exceed 10 feet, the pressure being mainly due to friction in the pipe. In a day's run of eleven hours, 500 pounds of hard coal, at \$6.75 per ton, is used, the average annual consumption being 6 to 12 tons. The crops irrigated are dandelion, kale, spinach, corn, and celery. Celery is irrigated every two weeks in dry weather, receiving about four irrigations per crop. Sweet corn produces 300 bushels per acre, with about 60 ears per bushel. The corn is first harvested July 17. Irrigation increases the value of the crops 20 to 50 per cent, according to the rainfall. An increase of 50 per cent is obtained only when the rainfall is very light.

RHODE ISLAND.

No. 57. D. N. Potter, of Providence County, irrigates 22 acres in beets, lettuce, celery, and cucumbers from a pond. A duplex steam pump forces the water through 400 feet of 3-inch pipe and 1,000 feet of 2-inch pipe provided with 2-inch branches. The water is distributed by a 1-inch hose provided with ½-inch nozzles, the maximum length of hose employed being 200 feet. The supply is sufficient for two nozzles. In addition the greenhouse consumes 5,000 gallons of water in three hours. Part of the piping is buried, and the other part, which is laid on the surface of the ground, is taken up every winter. The ground is usually irrigated from 3.30 p. m. to 7 p. m. Four hundred pounds of soft coal, costing \$4.10 per ton, is used in a ten-hour run, about 50 tons being used in a season.

The soil is a sandy loam 15 inches deep, with a light loam subsoil. One man will irrigate one acre in nine hours. In dry weather the land is irrigated not more than twice a week nor more than six times in a season. The total cost of the plant was \$1,700.

Carrots, parsnips, rhubarb, corn, and beans are very seldom irrigated. Cucumbers in the hotbeds are irrigated every two days. Two to three crops are grown on the same soil. Irrigation will generally produce one extra crop, will make the crops much earlier, and increase the yield fully 25 per cent. Irrigation increases the value of the celery crop fully one-third.

No. 58. C. W. Patt & Son, of Providence County, irrigate 10 acres in celery from a creek. A vertical boiler supplies steam at 40 pounds to a direct-acting steam pump run at 40 strokes per minute. The water is forced under a pressure of 80 to 100 pounds into a 3-inch distributing pipe 800 feet in length which runs through the farm and is provided with outlets for 2½-inch hose. The land is irrigated entirely by one 2½-inch fire hose with a 1-inch nozzle. The hose is in 50-foot lengths. In irrigating one length is uncoupled and the nozzle is screwed onto the next every fifteen minutes without shutting off the water. Every forty-five minutes the hose is changed to another outlet on the main pipe line, the plant being shut down for fifteen minutes. The hose will irrigate one acre in an hour. Water is applied in dry weather every two to three days from June through September.

The soil is a sandy and heavy loam 18 inches deep, with an open subsoil. The fuel is hard coal, costing \$6.75 per ton. In a ten-hour run 200 pounds are burned, and about 8 tons in a season. One man is required to operate the pumping plant. The owner estimates that the gain in the yield of celery is at least 25 per cent.

The same owners irrigate 22 acres planted in radishes, celery, lettuce, spinach, beets, and parsley. These crops are irrigated every week in dry weather, except celery, which is irrigated twice a week.

A 50-horsepower horizontal boiler supplies steam to a duplex pump, which draws its supply from a creek nearby and delivers water to a 3-inch main at 140 pounds pressure, the vertical lift being 32 feet. It is run at 60 strokes per minute and supplies five 1-inch hose streams. The suction-pipe is 5 inches in diameter and 550 feet long. The 3-inch main is 1,500 feet long and is provided with 2-inch, 1½-inch, and 1¼-inch branch pipes fitted with 1-inch hose connections with ½-inch nozzles. The greatest length of 1-inch hose used is 100 feet. One stream will irrigate one acre in three hours. One ton of soft coal at \$3.40 will run the plant fourteen hours.

METHODS OF IRRIGATION.

Of something over 60 plants described in the preceding pages 25 use the furrow system, usually supplying water through pipes and hose, 17 use hose sprinkling, 8 use single water witches, and 18 use multiple water-witch systems. Twelve of these plants use more than one system, and about 10 are not reported. While the data are too variable to form a basis for reliable statements as to relative advantages, it is interesting to notice what averages the data show.

The size of a single stream of water averages 24 gallons per minute for each furrow, 44 for each hose nozzle, and about 4 gallons per minute for each sprinkler used. The time during which water is run in one place averages half an hour for the furrow system and nearly an hour with sprinklers. None of the plants using furrows or single sprinklers requires more than one man to look after the water, usually using not more than half of his time during an irrigation. Where hose sprinkling is used the entire time of one man is required for each nozzle during an irrigation, the average number of men being three. With multiple sprinklers, owing to the necessity of moving long lines of pipe, a number of men are required for a short time when the water is changed, only a small fraction of their time being taken for this purpose. The number of men required averages three, the work of irrigation taking about one-fourth of their time. Where a complete system of piping is installed, one man can look after an entire plant.

In estimating the labor cost of one irrigation, the actual time put in by each man must be considered. In the following averages labor is taken at \$1.50 per day, and it is assumed that five minutes are required to change the water in a furrow or to move a sprinkler. Where multiple witches are used, five minutes are allowed for moving the first of a system of bars, and three minutes for each additional bar, except on the larger places where a number of men must be called from greater distances, in which cases ten minutes are allowed for the first bar. On this basis the labor cost of one irrigation by furrows runs from \$0.30 to \$1.20, averaging \$0.75 per acre. With hose sprinkling the average is \$1.80 per acre; with single witches, \$1.12, and with multiple sprinklers \$2.40, ranging in the latter case from \$0.45 to \$8.70 per acre. The depth applied, however, is 1.3 inches by furrows, 0.6 inch by hose sprinkling, 0.3 inch by single sprinklers, and 1.8 by multiple witches; making the average labor cost of applying 1 acre-foot of water, \$7.10 by furrows, \$34.80 by hose, \$34.40 by single sprinklers, and \$16.10 by multiple sprinklers, but where a complete system of pipes is installed the cost runs as low as \$3.50 per acre-foot. It should also be noticed that the labor of applying water with sprinklers is not increased by lengthening the time and the amount of water used since only a definite number of changes are required to irrigate a given piece of land once. With hose or furrow irrigation the labor is proportional to

the amount of water applied, and can only be decreased by increasing the flow of water handled by one man.

Owing to the interruption of other work, when a number of men must be assembled every hour or so to change the water, it is usually much better to arrange the distribution so that one man can use his entire time to good advantage. For instance, one farmer uses several bars of $\frac{3}{4}$ -inch pipe 34 feet long, provided with three sprinklers each which one man can handle easily. Better work is likely to be done where one man devotes his whole time to irrigation. Where the water supply is not sufficient to require the entire time of one man, it would be well to arrange the system so that one man can do all the work when irrigation is required.

The reason for the prevalence in the East of the sprinkling method of irrigation, which is practically unknown in arid sections, lies in two important differences in the conditions of irrigation practice. First, the quantity of water applied in one irrigation in the East must be small, owing to the risk of sudden and heavy rains which would swamp a crop if falling soon after a heavy irrigation; and, second, the soils used for truck farming in the East are not, as a rule, so capable of storing and retaining water as the arid soils, so that a heavy irrigation once a month will not answer the needs of garden crops in the East. With the sprinkling system it is possible to apply uniformly as small a quantity of water as desired, while with furrows enough must be applied to run through the furrows and soak laterally to the roots of the plants.

In brief, the advantages of the sprinkling system are that there is no loss of space if the main pipes are laid underground, and no loss from leakage; it is applicable to uneven ground and hillsides, since water is delivered under pressure; no special preparation of the surface is required, and plants may be set as close as desired; a very small flow of water may be utilized, and a light irrigation may be very quickly applied in emergency. Its disadvantages are the great first cost for pipe and connections; the high pressure head which must be overcome when water is pumped; the excessive cost of city water where used; and the great expense of applying water and maintaining an elaborate system.

The advantages of the furrow system are its cheapness and simplicity, requiring only ordinary farm tools to lay out; the ease with which one man can handle a large stream of water; the fact that water is applied by gravity and need not be pumped higher than the land to be watered, dispensing with high storage tanks. Water may be applied at any time of day without danger of scalding the plants, since the foliage is not wet and evaporation from the ground surface is reduced to a minimum. The disadvantages are: The loss of space where head laterals are used, and the expense of piping, where pipes are used instead of open-head ditches; the cost of leveling and smoothing land

so that the furrows may carry the water without flooding; the expense of furrowing out before each irrigation and of cultivating afterwards, and the necessity of planting far enough apart for horse cultivation; the difficulty of applying water evenly in very sandy soil, and the loss of water by seepage in head ditches, especially where the flow used is small.

In irrigating with a hose by hand many use no nozzle at all, simply putting the thumb over the end of the hose to make a fine spray. A cheap nozzle is often made by flattening the end of a piece of ordinary pipe. Others use a fine-hole sprinkler or some form of patent adjustable nozzle.

Where sprinklers are used, the simple forms shown in figures 5 and 6 are much in favor.

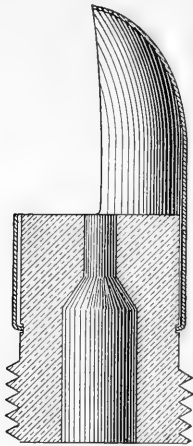

Fig. 5.—Simple nozzle.

One widely used type of water witch (fig. 6) consists of a small revolving device with two concave horns which revolve, owing to the reaction of the water flowing between them. These sprinklers operate with a pressure of 15 to 30 pounds, and will cover a circle 15 to 30 feet in diameter. Their simplicity and cheapness have led to their wide adoption. The water passages through the sprinkler are fairly large and not easily clogged. Many irrigators use small brass plugs with one small hole drilled in the center. Revolving-arm sprinklers are very little used, being expensive and too easily clogged.

The various arrangements of multiple sprinklers are described above in connection with the detailed data regarding truck-irrigation plants, and a few details are shown in figure 7.

Where pipe is laid on the surface, it is frequently taken up and stored away during the winter, making a great deal of labor. It is usually better to bury the pipes below the depth of cultivation, provision being made to drain the water out, so as to prevent freezing. In many cases there is a tendency to buy too small pipe for mains, which needlessly increases the pumping head, and thus the fuel cost.

THE COST OF IRRIGATION.

The cost of irrigation includes, besides the cost of applying water already discussed, both interest and repairs on the plant and fuel and attendance for pumping. Where city water is used the fuel and attendance are included in the rate paid for water. Interest and taxes may be taken at 7 per cent of the cost of the plant, and depreciation, repairs, and renewals at 13 per cent, or 20 per cent annually as the total fixed charges on small pumping plants. This expense is constant whether the plant is used or not.

Seven plants using city water irrigate 61 acres, the average cost of plant per acre being \$44, while the cost per acre on individual plants varies from \$12 on farm No. 18 to \$188 on No. 44. The average fixed charges on the basis assumed are thus nearly \$9 per acre annually.

Six gravity systems irrigate 15 acres, the first cost varying from practically nothing in Nos. 11 and 12 to \$100 per acre in No. 6, where a supply had to be developed.

Seventeen pumping plants, irrigating 388 acres, cost an average of \$74 per acre, the least cost being \$27 for No. 29 and the greatest being \$455 for No. 27. The average fixed charges may be put at about \$15 per acre.

The cost of city water is quite uniform, averaging in fifteen cases \$1.11 per 1,000 cubic feet, or about \$48 per acre-foot. As the depth

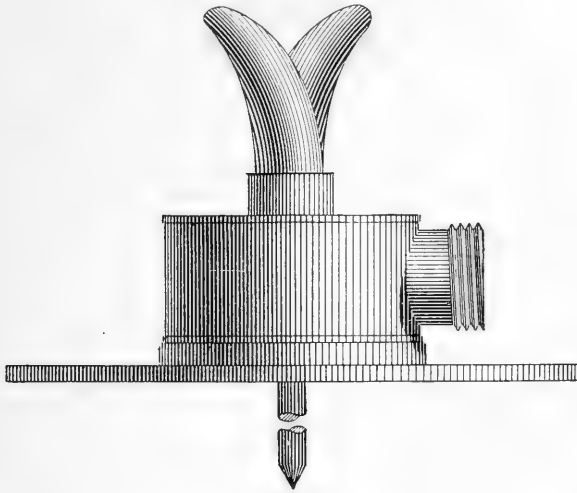

FIG. 6.—Nozzle.

applied averages about 4 inches, the cost of city water per acre is \$16.

The reasonable cost of pumping can hardly be determined from the small amount of data available, but comparison with skillful western practice shows that the expense is unnecessarily high, due to several causes. In most pumping plants in the West the amount of piping used is small, and the pressure against which the pump operates is practically the lift alone. In the East, with the pipe distributing systems, the friction head and discharge head are often far in excess of the actual lift, necessitating much larger power plants and fuel consumption. Any system of sprinkling requires at least 20 feet discharge head for hand sprinkling and twice as much for water witches, and larger heads are decidedly preferable. In any extended distributing pipe system there will necessarily be large friction losses in the

pipe, since pipes large enough to cut down this loss would be too expensive.

The actual lifts of pumping plants in the East vary from 13 to 80 feet, while total pressure heads of 150 to 200 feet are not uncommon, and in one plant the pressure head was 340 feet, of which only 32 feet was actual lift. In other words, the power was eleven times that required to lift the water. On an average, the total head is probably three times the lift. Where elevated tanks are used, the work of pumping is often increased two or three times. In many places the power plant installed is fully six times as large as would be necessary were the water to be elevated only to the highest point of the ground to be irrigated.

Of twelve cases, the average of the cost per acre-foot for fuel and labor is \$13.15 where steam power is used. Adding to this the fixed

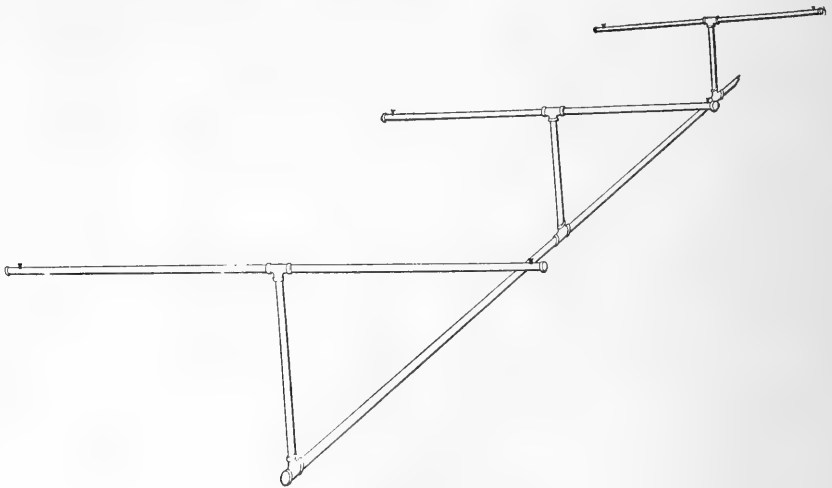

FIG. 7.—Multiple sprinkler.

charges given above, the total cost of providing and distributing water, but not applying it, is \$28 per acre-foot. A cost of \$28 per acre-foot for water delivered at the point where it is ready to be applied to the fields is very high in comparison with western costs.

In six plants using gasoline engines the average cost for gasoline per acre-foot pumped is \$2.91, as against \$6.18 for fuel alone for coal plants. This difference is due to the greater heads under which the coal plants operate—perhaps four times the average head for the gasoline plants—and to the use of direct-acting steam pumps, which are very wasteful of steam. Gasoline plants should be more widely adopted in the East, except where steam plants obtain their steam from boilers used for other purposes, such as heating in the winter

time, and thus effect a saving in first cost over the gasoline plant. The average steam plant under the conditions observed costs over four times as much for fuel and attendance as the average gasoline plant.

In many cases the use of a reservoir holding from one to three days' supply of the pump would greatly facilitate irrigation. These reservoirs may be constructed by throwing up earth embankments, the inside slope of the embankment being 1 vertical to 2 or 3 horizontal and the outside slope 1 vertical to $1\frac{1}{2}$ or 2 horizontal, the top of the bank being about 4 feet wide. The banks should be constructed as far as possible of water-tight material, such as clay or "puddle," and should be carried down to a water-tight stratum by means of a carefully filled ditch, which will thoroughly bind the bank to the original surface. If the material at hand will not hold water the reservoir must be lined. Concrete, asphalt, and tar mixtures are used for this purpose. Reservoir embankments, when suitable material for construction is near at hand, should be built for 15 to 25 cents per cubic yard in the East. To this must be added the cost of lining, if necessary. Cement will probably cost 10 to 15 cents per square foot laid 4 inches thick, and tar mixtures will be much cheaper.

RETURNS FROM IRRIGATION.

In a humid country it is especially hard to get at the probable returns from irrigation, owing to great variations in the distribution of rainfall, the nature of the soil and the subsoil, and to the effects of severe rains. For example, in a dry year unirrigated crops may be a total failure and irrigated crops be as large as ever, while in a wet year irrigation may prove a positive detriment. An estimate of the real value of irrigation should show the average results obtained during a period sufficiently long to give a fair average of climatic conditions. Only the State experiment stations are in a position to obtain reliable figures for long periods and to compare directly the results of irrigated and unirrigated crops. There is at present little reliable information on this question. Still the estimates of various farmers as presented in this report may give a better understanding of the problem and present a fair idea of the benefits to be obtained.

The average yearly value of truck crops in nine cases was given as \$1,030 per acre, of which value the irrigators estimated that \$330 was due to irrigation, or an increase of 47 per cent. Other estimates run usually 30 to 50 per cent. As the cost of irrigation usually lies between \$30 and \$100 per acre, it is fair to assume an average profit of \$200 or more per acre due to irrigation.

In order to form some idea of the probable benefit of irrigating field crops, many farmers in Pennsylvania were asked the following

questions regarding the various crops: What is the yield per acre in an average year, and what is the corresponding yield in seasons when the rainfall is ample? The replies have been compiled, and the averages are presented below as giving merely a preliminary indication of the possibilities of irrigation. Of course, damage by severe storms and frost would affect irrigated and unirrigated crops alike.

Comparative yields in wet and dry years.

Crop.	Average yield per acre.	Yield per acre in a wet year.	Assumed price.	Value average crop.	Increased value in good year.
Corn.....bushels..	48	64	\$0.60	\$28.80	\$14.40
Wheat.....do.....	20	28	.83	16.60	6.64
Rye.....do.....	20	25			
Oats.....do.....	40	52	.37	14.80	4.44
Tobacco.....pounds..	1,330	1,700	.08	106.40	29.60
Timothy.....tons.....	1.6	2.1	13.00	20.80	6.50
Clover.....do.....	1.6	2.1	11.00	17.60	5.50

CONCLUSION.

The data presented seem to warrant the following conclusions:

The irrigation of meadows and truck farms is an established and profitable practice in the North Atlantic States, while the profitable irrigation of field crops has not been demonstrated as yet.

The methods employed are very expensive compared with western practice, but are the outgrowth of peculiar conditions and meet the requirement of very small applications of water.

The quantity of water required by truck crops either as rain or irrigation is about 1 inch in depth every week, and in the light sandy soils generally used it should be applied in quantities not exceeding 1 inch at a time.

O





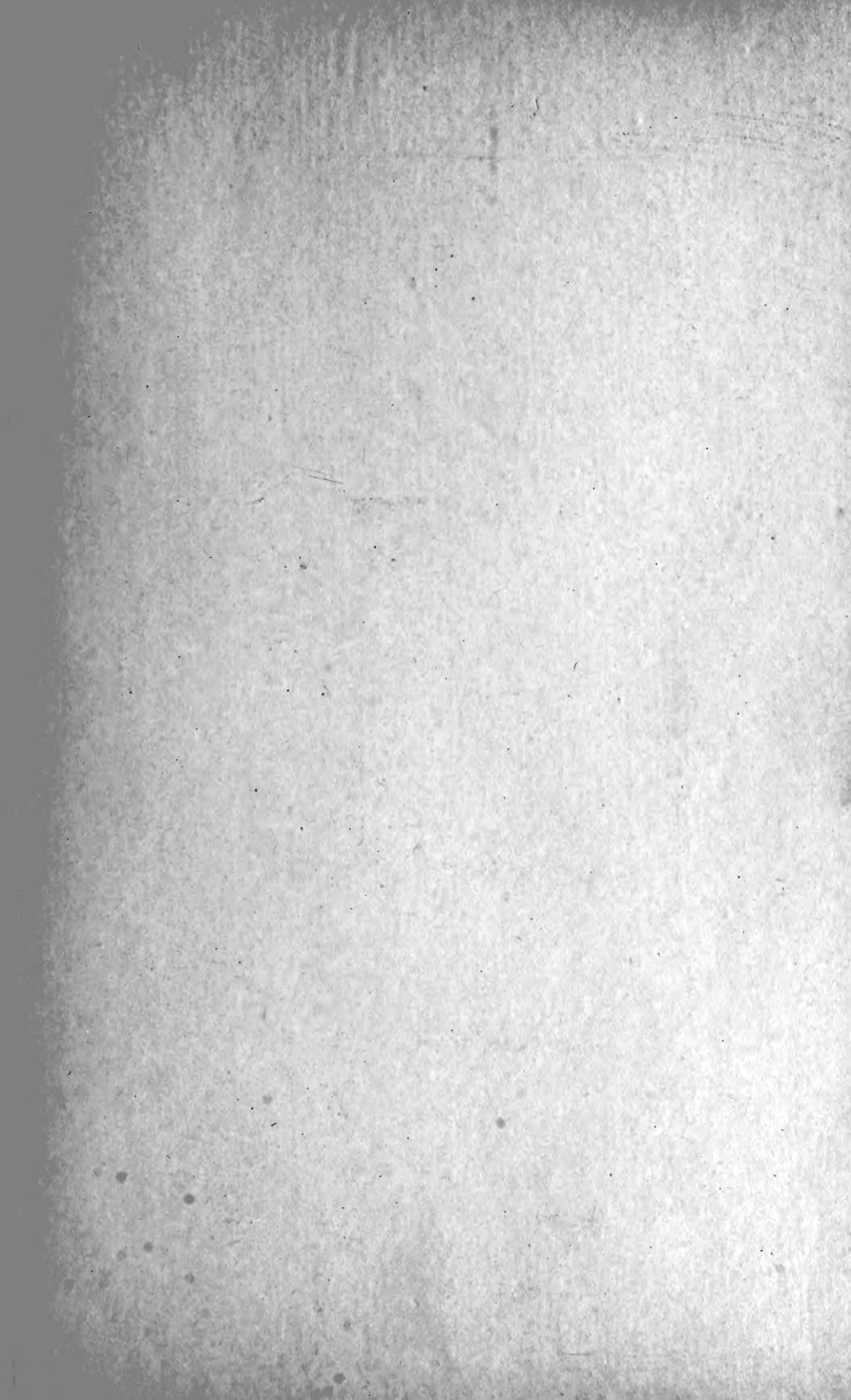

LIBRARY OF CONGRESS



00027610079